

Contents

50CLFU61.5
 80CLFU61.5
 80CLMFU61.5
 80CLFU62.2
 80CLMFU62.2
 80CLFU63.7
 80CLMFU63.7
 100CLFU62.2
 100CLFU63.7
 100CLMFU63.7

Section	Page
Specifications	1702
Selection Chart	1703
Performance Curves	1704
Dimensions	1710
Sectional View	1717
QDC Information	1900
Motor Data	2000
motor electrical specifications	
cable data	
wiring diagrams	
motor electrical data	

Model CLFU

EBARA PRO Cast Sewage Pumps

Model Designation

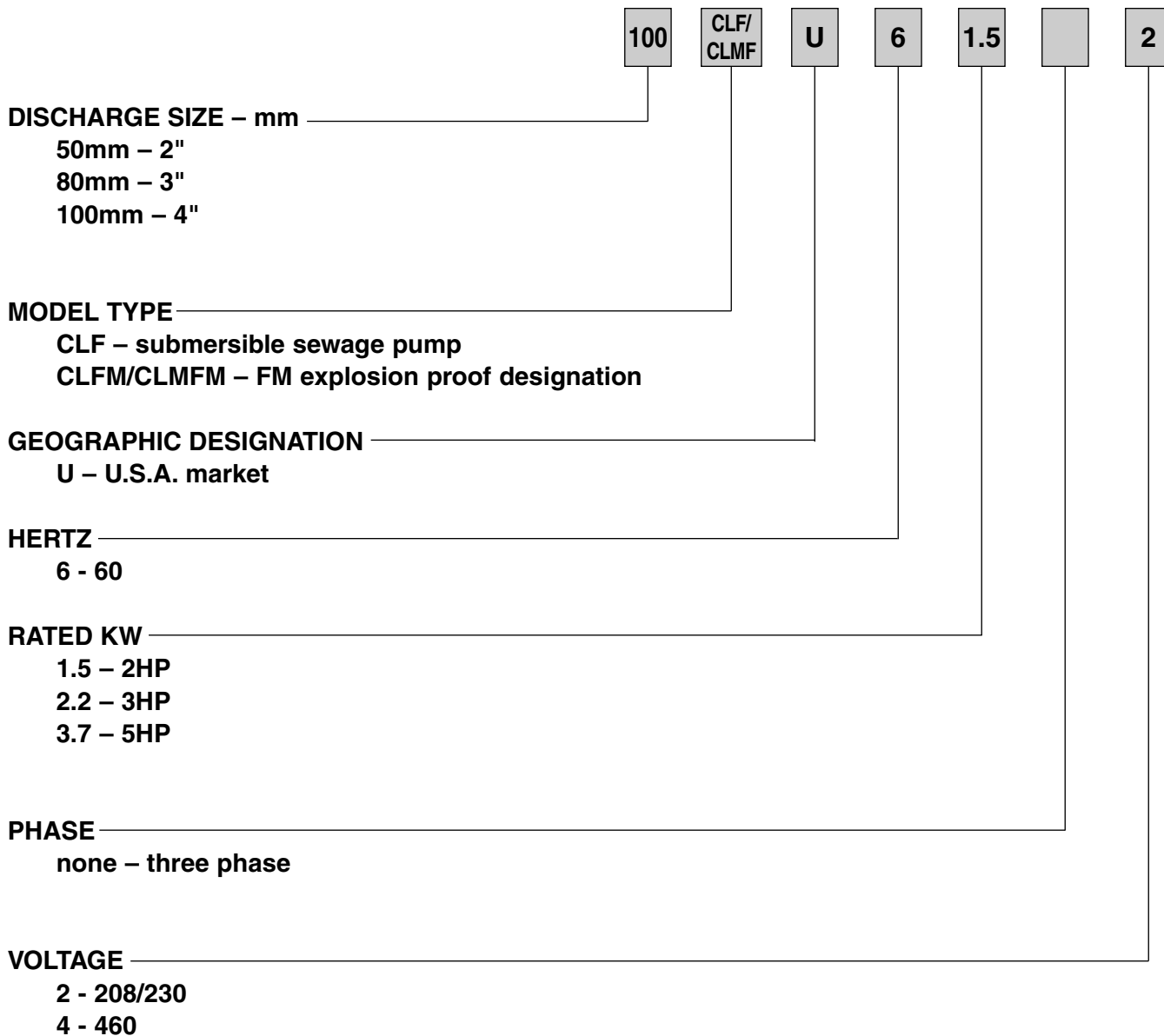

Model CLFU

EBARA PRO Cast Sewage Pumps

Specifications

	Standard	Optional
Size	2, 3, 4 inch	
Range of HP Range of Performance	2 to 5 HP Capacity 13 to 550 GPM Head 7 to 65 feet	
Limitation Maximum Water Temperature	104°F (40°C)	
Synchronous Speed	1800 RPM	
Materials Casing Impeller Shaft Motor Frame Fastener	Cast Iron Cast Iron 403 Stainless Steel (2 to 5HP) Cast Iron 304 Stainless Steel	
Mechanical Seal Material – Upper Side Material – Lower Side Impeller Type Bearing Motor Three Phase Service Factor Motor Protection Accessories	Double Mechanical Seal Carbon/Ceramic Silicon Carbide/Silicon Carbide Semi-open Prelubricated Ball Bearing Insulation Class F 208/230/460V 1.15 Thermal Detector – Klixons Mechanical Seal Leakage Detector – Float Switch Submersible cable 33 ft.	Tungsten carbide/Tungsten carbide Tungsten carbide/Tungsten carbide FM Explosion Proof, Class 1, Division 1, Group C, D ____ ft. (customer specified) QDC System

Three Phase 60Hz

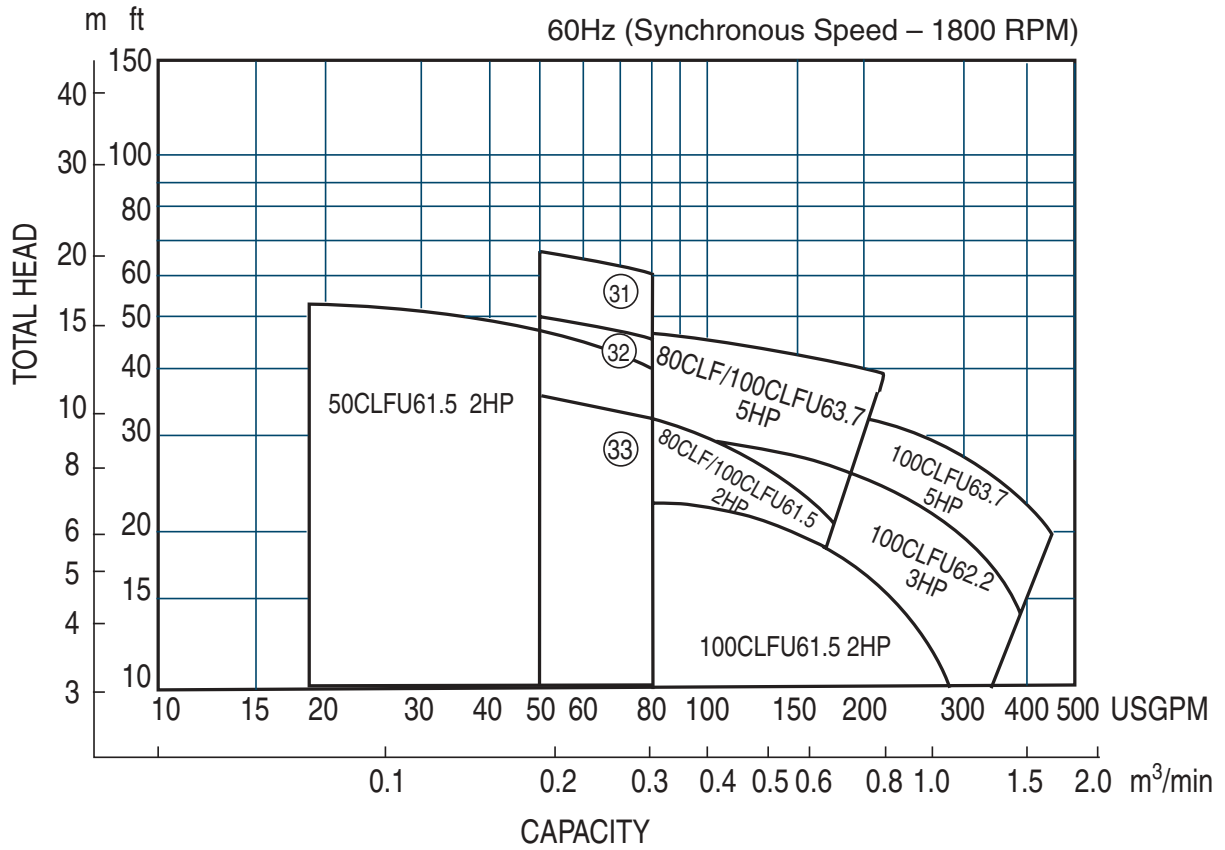

31	80CLMFU63.7	5HP
32	80CLMFU62.2	3HP
33	80CLMFU61.5	2HP

Model CLFU

EBARA PRO Cast Sewage Pumps

Performance Curves

50CLF61.5 (2HP) Synchronous Speed: 1800 RPM

2, 3 inch Discharge

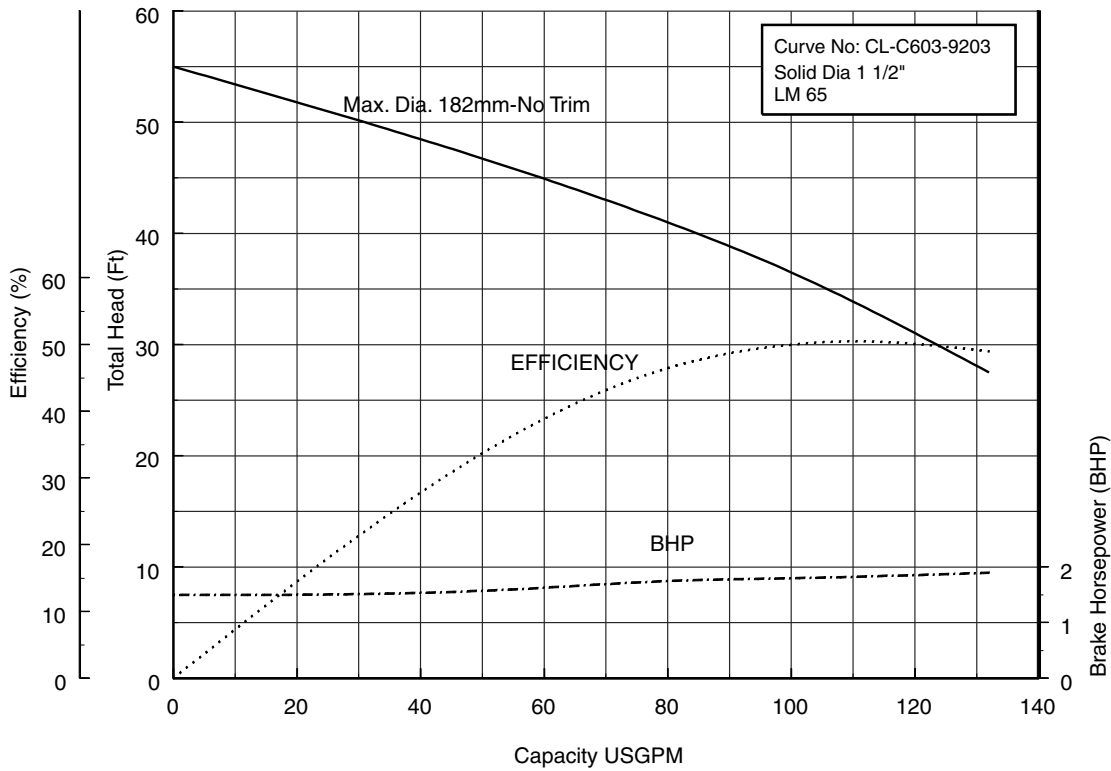

80CLF61.5 (2HP) Synchronous Speed: 1800 RPM

3, 4 inch Discharge

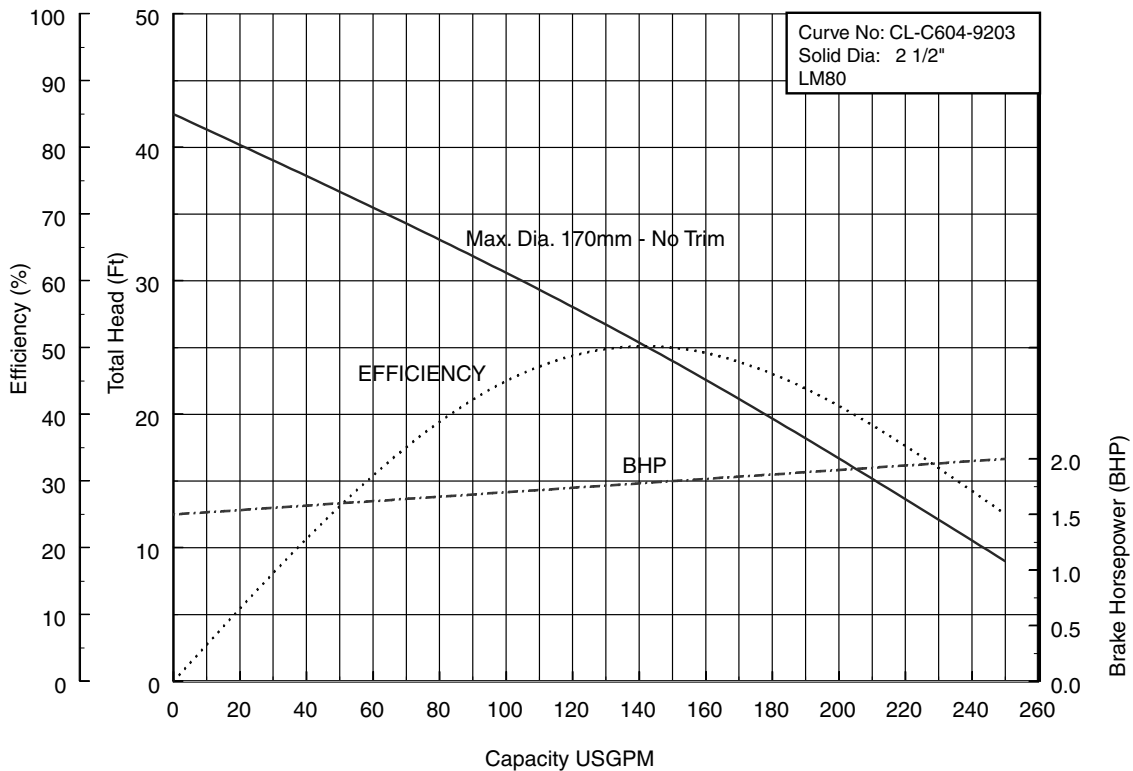

Model CLFU

EBARA PRO Cast Sewage Pumps

Performance Curves

80CLMF61.5 (2HP) Synchronous Speed: 1800 RPM

3, 4 inch Discharge

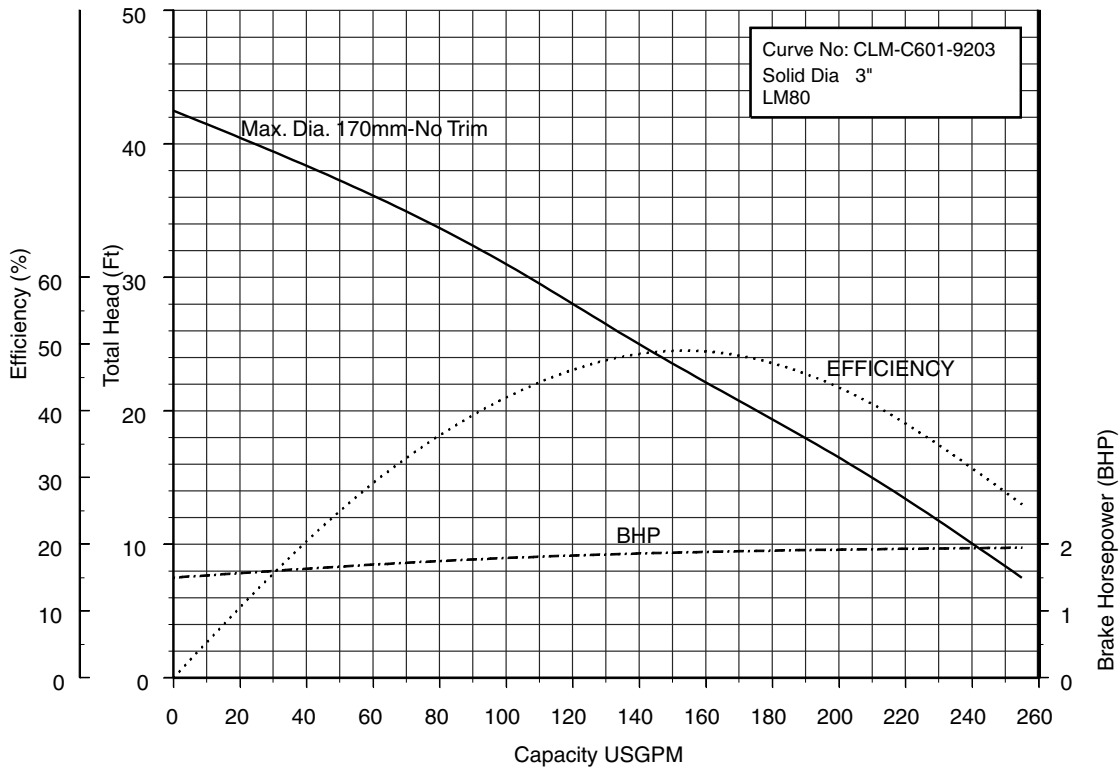

80CLF62.2 (3HP) Synchronous Speed: 1800 RPM

3, 4 inch Discharge

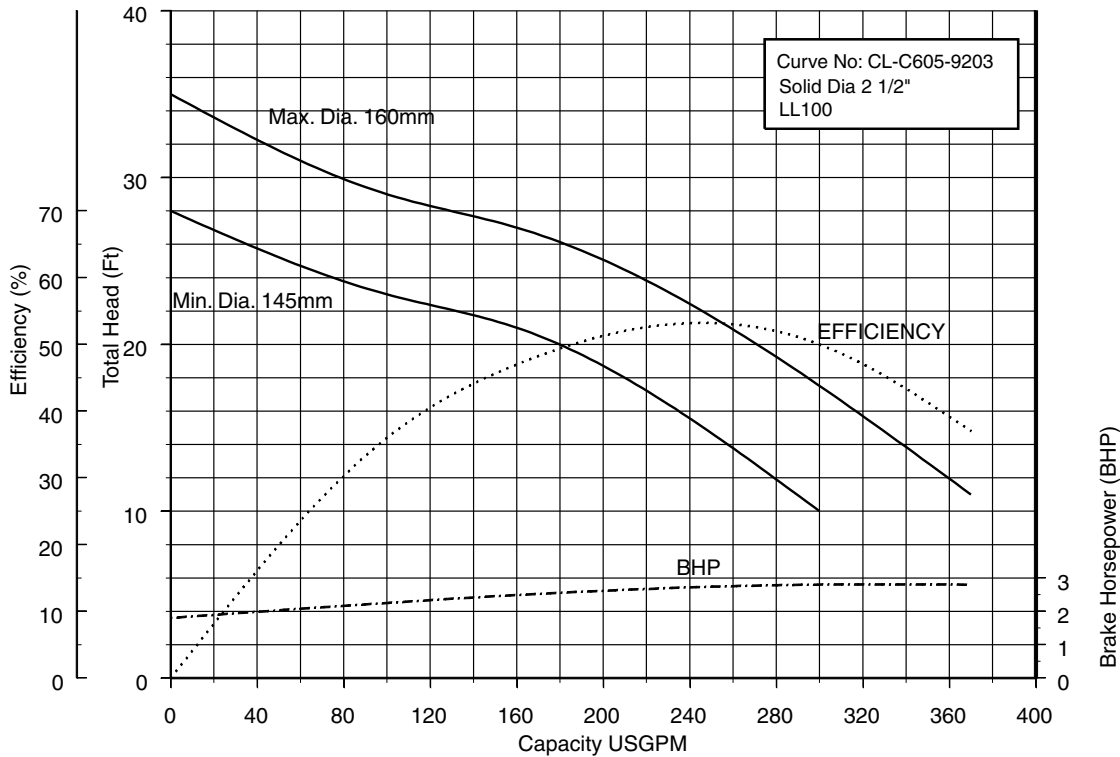

Model CLFU

EBARA PRO Cast Sewage Pumps

Performance Curves

80CLMF62.2 (3HP) Synchronous Speed: 1800 RPM

3, 4 inch Discharge

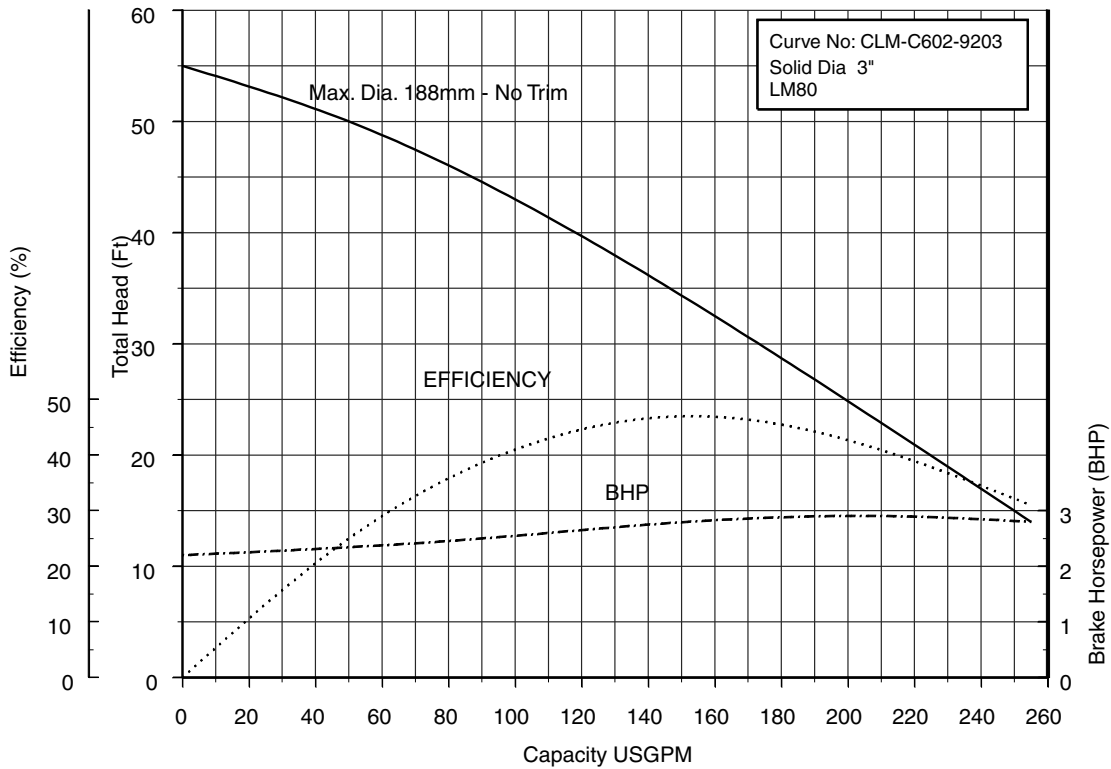

80CLF63.7 (5HP) Synchronous Speed: 1800 RPM

3, 4 inch Discharge

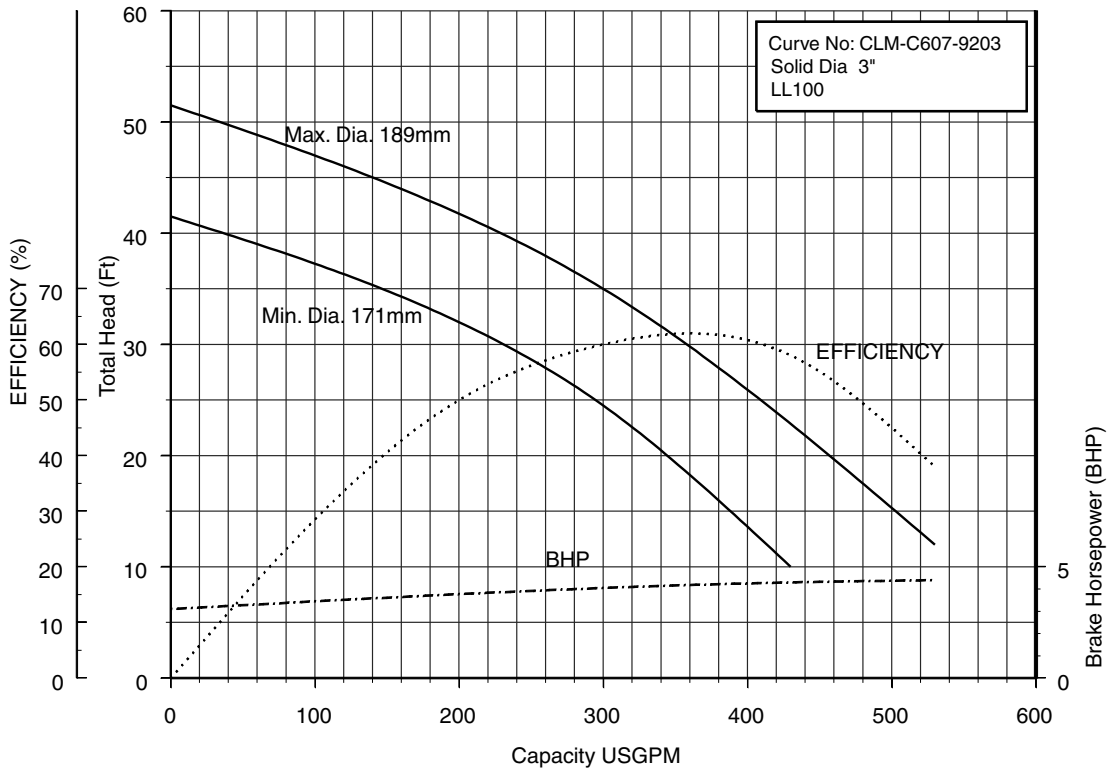

Model CLFU

EBARA PRO Cast Sewage Pumps

Performance Curves

80CLMF63.7 (5HP) Synchronous Speed: 1800 RPM

3, 4 inch Discharge

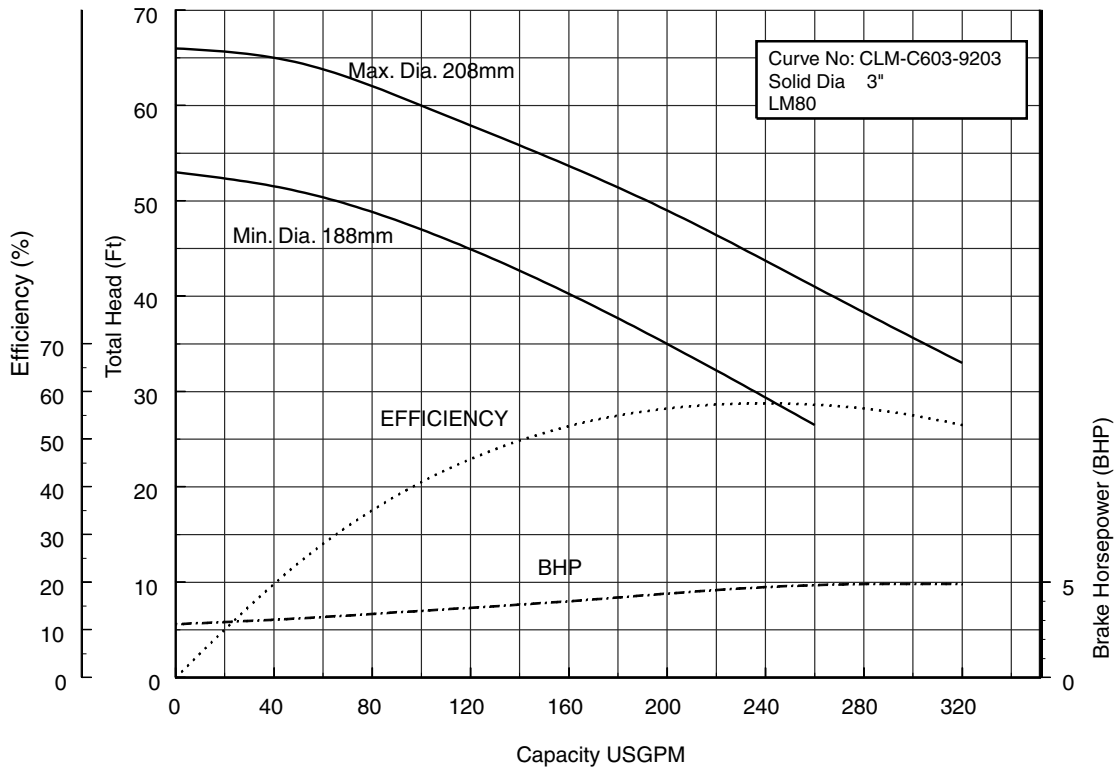

100CLF61.5 (2HP) Synchronous Speed: 1800 RPM

3, 4 inch Discharge

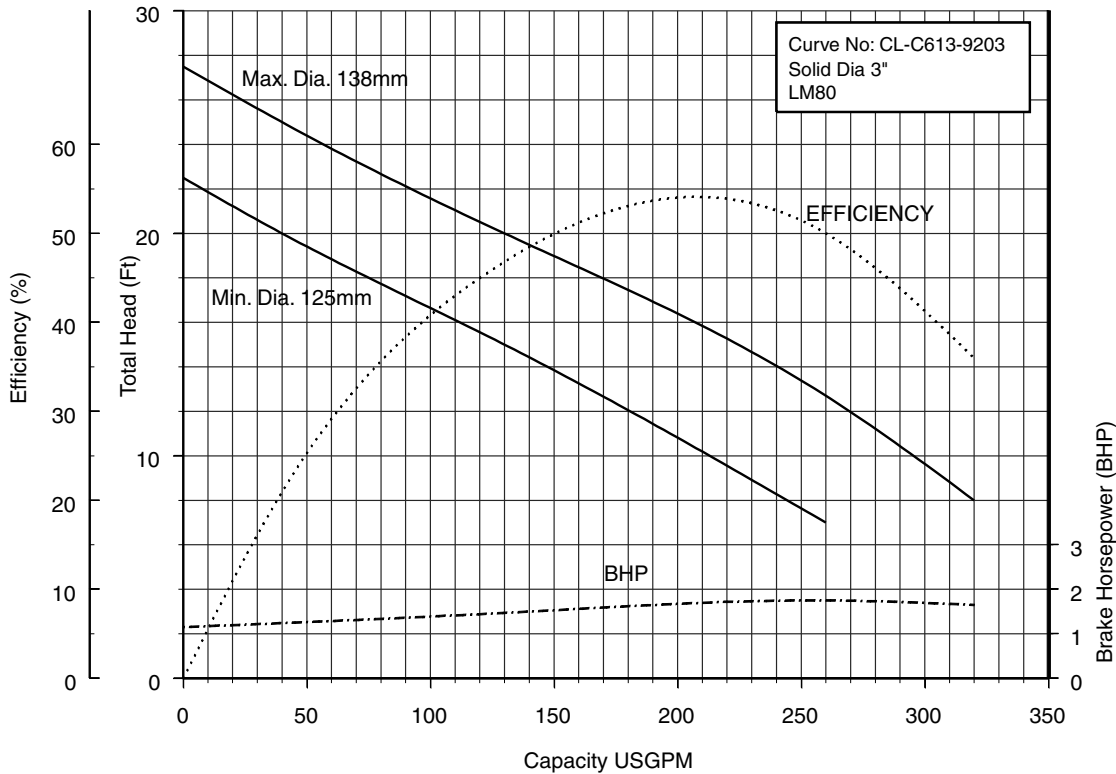

Model CLFU

EBARA PRO Cast Sewage Pumps

Performance Curves

100CLF62.2 (3HP) Synchronous Speed: 1800 RPM

3, 4 inch Discharge

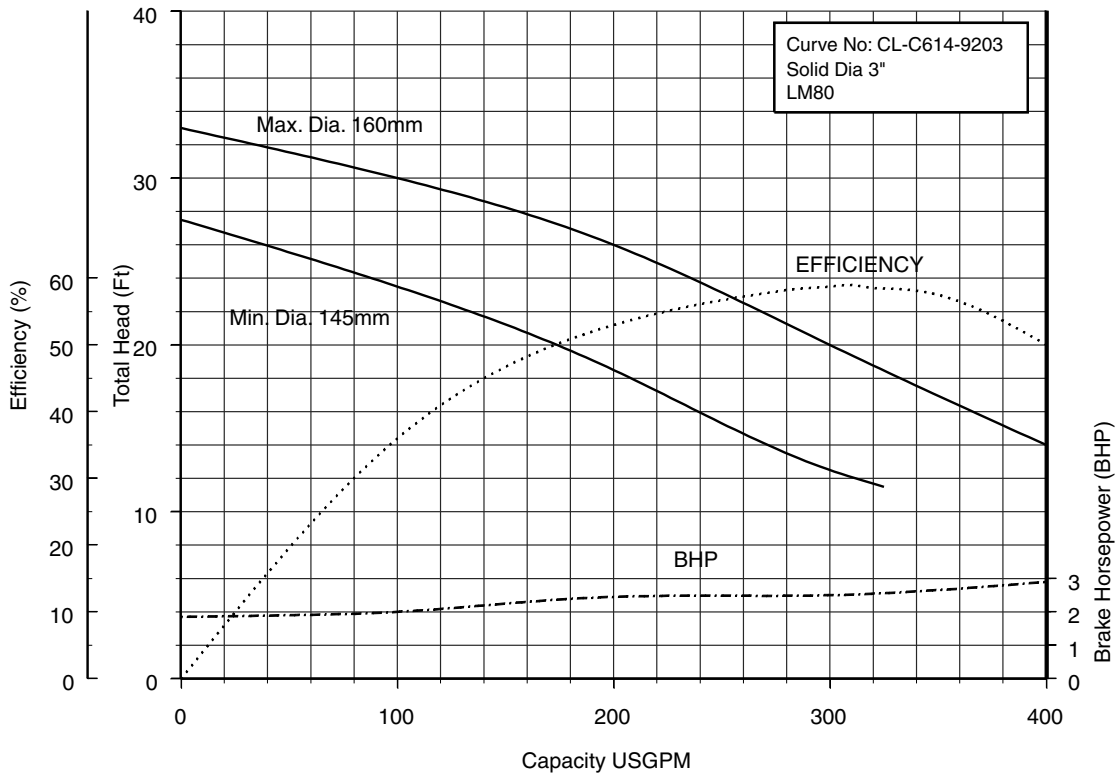

100CLMF62.2 (3HP) Synchronous Speed: 1800 RPM

3, 4 inch Discharge

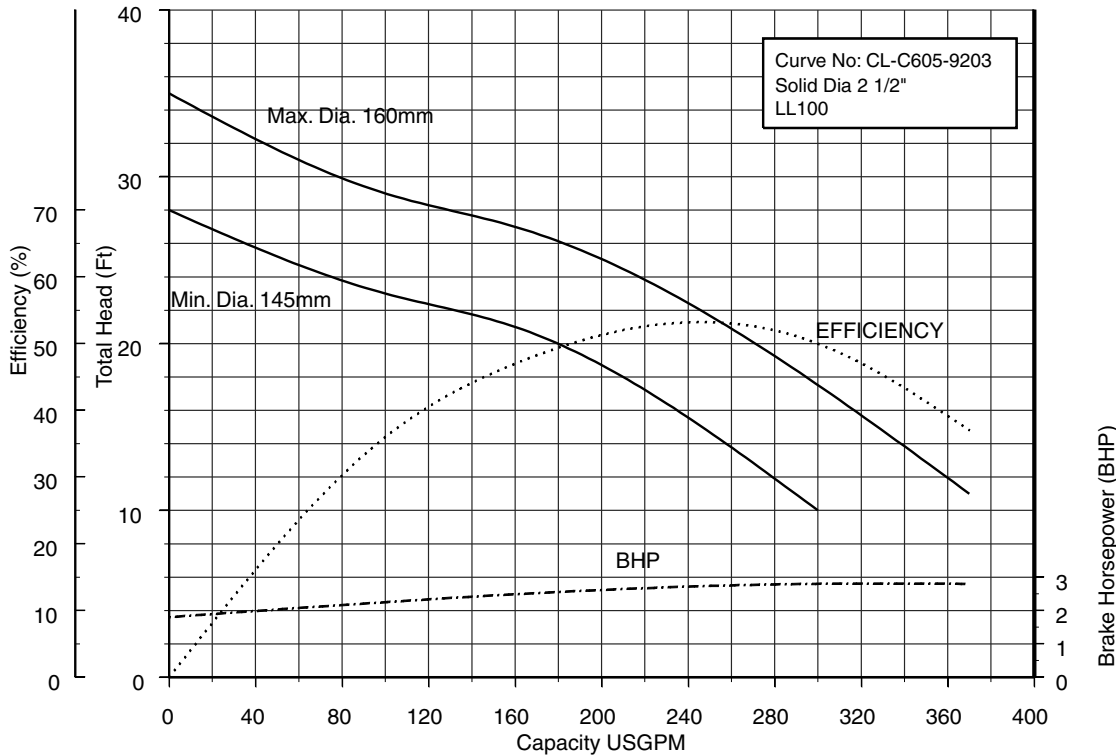

Model CLFU

EBARA PRO Cast Sewage Pumps

Performance Curves

100CLF63.7 (5HP) Synchronous Speed: 1800 RPM

3, 4 inch Discharge

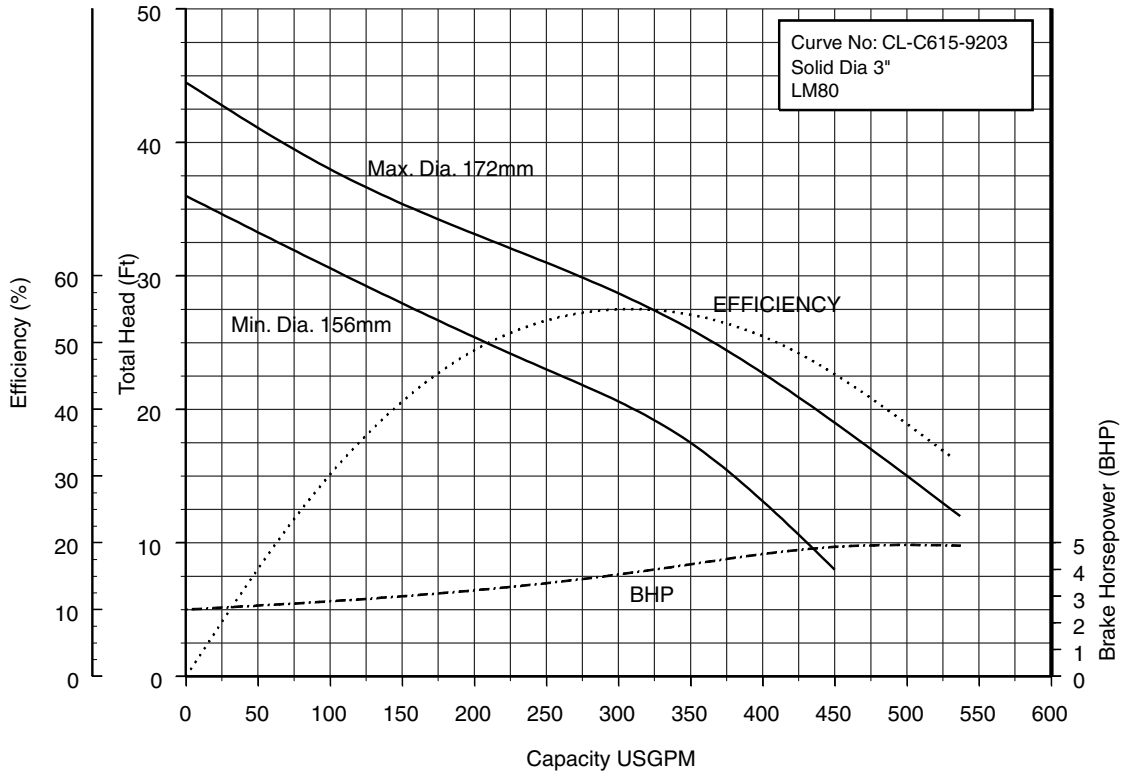

100CLMF63.7 (5HP) Synchronous Speed: 1800 RPM

3, 4 inch Discharge

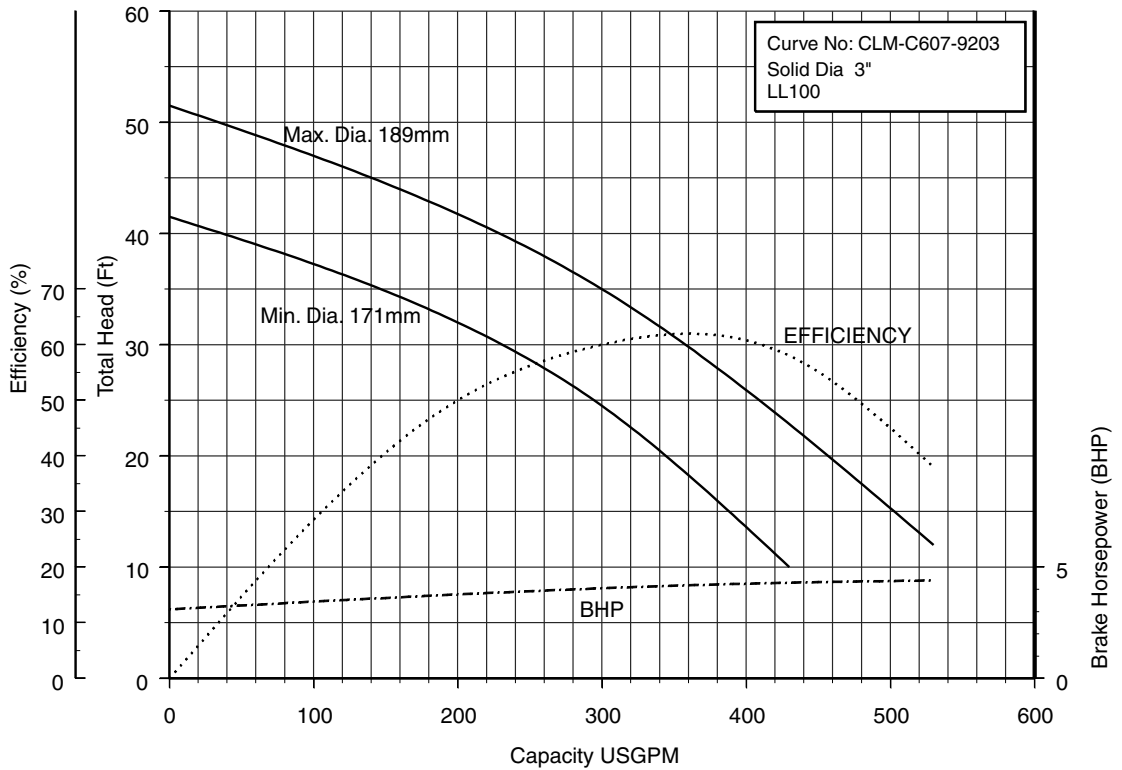

Model CLFU

EBARA PRO Cast Sewage Pumps

Dimensions

80CLMFU, 2 to 5HP

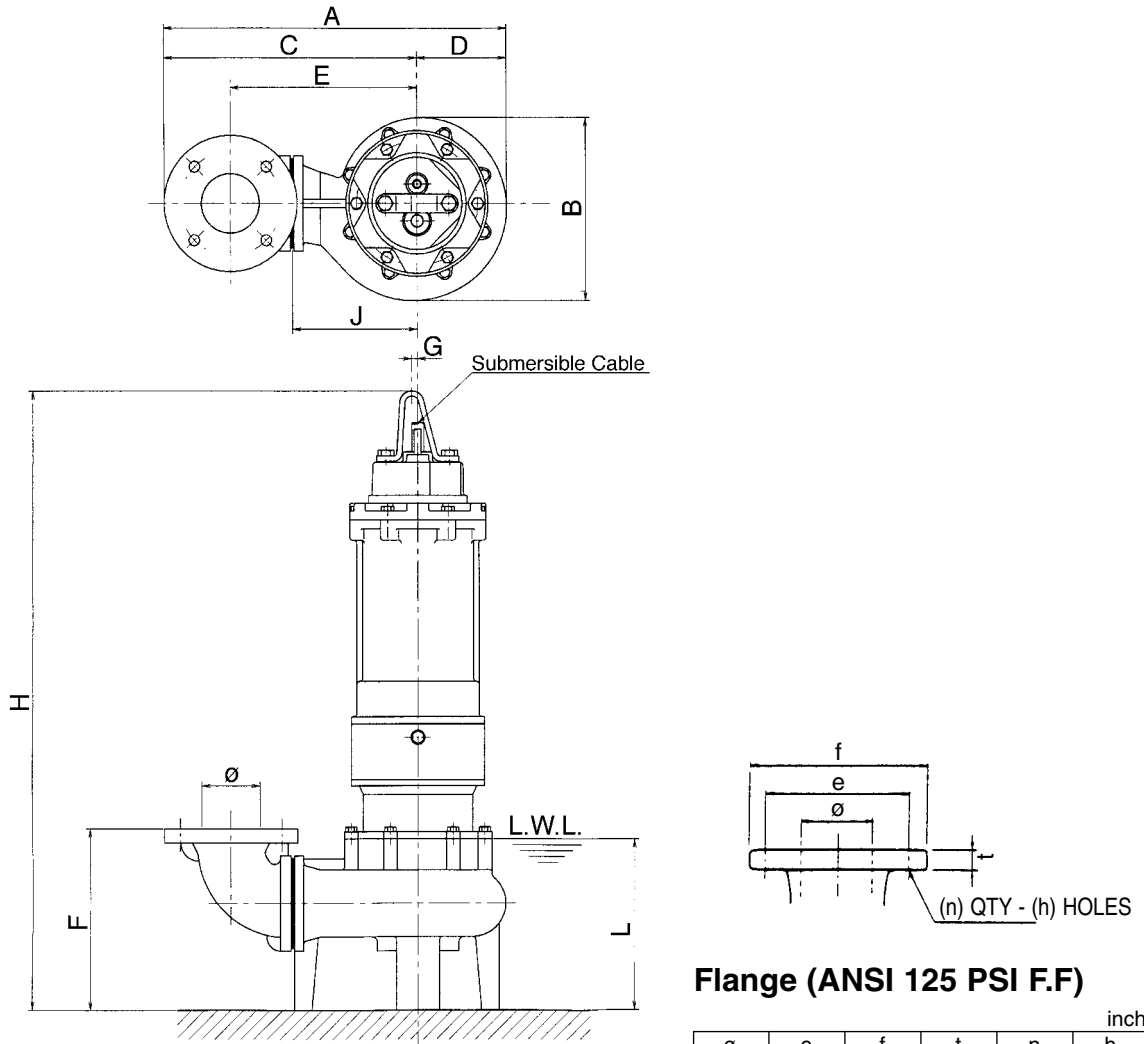

Flange (ANSI 125 PSI F.F)

inch					
ø	e	f	t	n	h
3	6	7½	¾	4	¾

mm					
ø	e	f	t	n	h
80	152	191	19	4	19

Dimensions: inch

PHASE	SIZE ø	MODEL	OUTPUT		PUMP & MOTOR										WEIGHT Lb
			kW	HP	A	B	C	D	E	F	G	H	J	L	
THREE	2/3	80CLMFU61.5	1.5	2	20¾	11½	15	5¾	11¼	8¹¹⁄₁₆	⁵⁄₁₆	28½	8¼	7¹⁄₁₆	157
		80CLMFU62.2	2.2	3	20¾	11½	15	5¾	11¼	8¹¹⁄₁₆	⁵⁄₁₆	29½	8¼	7½	188
		80CLMFU63.7	3.7	5	21¹⁄₁₆	12⅞	15⅜	6¹⁄₁₆	11⅝	8¹¹⁄₁₆	⁵⁄₁₆	31¹⁄₁₆	8¹¹⁄₁₆	7½	206

Dimensions: mm

PHASE	SIZE ø	MODEL	OUTPUT		PUMP & MOTOR										WEIGHT kg
			kW	HP	A	B	C	D	E	F	G	H	J	L	
THREE	80/100	80CLMFU61.5	1.5	2	527	292	381	146	285	220	8	724	210	180	71
		80CLMFU62.2	2.2	3	527	292	381	146	285	220	8	750	210	190	85
		80CLMFU63.7	3.7	5	545	308	391	154	295	220	8	789	220	190	93

***Note:** All 80DLFU dimensions are based on 3" discharge.



Model CLFU

EBARA PRO Cast Sewage Pumps

Dimensions

100CLFU, 2 to 5HP

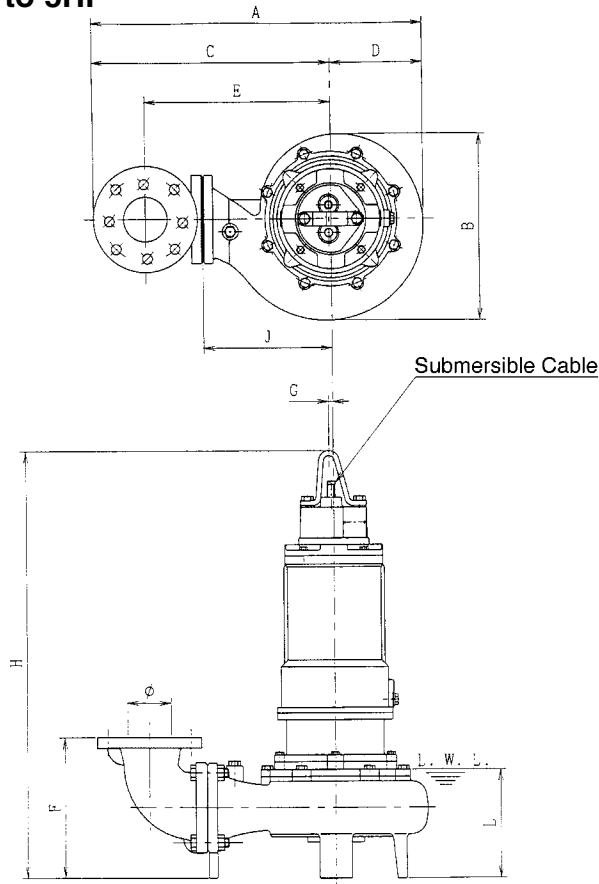

Flange (ANSI 125 PSI F.F)

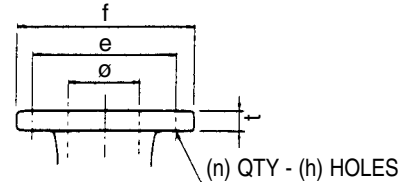

inch					
Ø	e	f	t	n	h
4	7 ¹ / ₂	9	¹⁵ / ₁₆	8	³ / ₄

mm					
Ø	e	f	t	n	h
100	191	229	24	8	19

Dimensions: inch

PHASE	SIZE Ø	MODEL	OUTPUT		PUMP & MOTOR								WEIGHT Lb		
			KW	HP	A	B	C	D	E	F	G	H		J	L
THREE	3/4	100CLFU61.5	1.5	2	21 ³ / ₄	10 ¹ / ₂	16 ⁹ / ₁₆	5 ¹ / ₄	12	10 ¹³ / ₁₆	⁵ / ₁₆	29 ¹⁵ / ₁₆	7 ⁷ / ₈	8 ¹¹ / ₁₆	170
		100CLFU62.2	2.2	3	22 ⁷ / ₈	11 ¹ / ₈	17 ⁵ / ₁₆	5 ⁹ / ₁₆	12 ¹³ / ₁₆	10 ¹³ / ₁₆	⁵ / ₁₆	30 ¹³ / ₁₆	8 ¹¹ / ₁₆	8 ¹¹ / ₁₆	198
		100CLFU63.7	3.7	5	22 ⁷ / ₈	11 ¹ / ₈	17 ⁹ / ₁₆	5 ⁹ / ₁₆	12 ¹³ / ₁₆	10 ¹³ / ₁₆	⁵ / ₁₆	32 ³ / ₈	8 ¹¹ / ₁₆	8 ¹¹ / ₁₆	216
	4/6	100CLFU67.5	7.5	10	28 ⁹ / ₁₆	15 ¹¹ / ₁₆	20 ¹¹ / ₁₆	7 ⁷ / ₈	16 ¹ / ₈	15	³ / ₈	37 ⁷ / ₁₆	11	11 ⁷ / ₁₆	395
		100CLFU611	11	15	28 ⁹ / ₁₆	15 ¹¹ / ₁₆	20 ¹¹ / ₁₆	7 ⁷ / ₈	16 ¹ / ₈	15	⁵ / ₁₆	41 ¹ / ₈	11	11 ⁷ / ₁₆	476
		100CLFU615	15	20	29 ³ / ₄	16 ⁷ / ₁₆	21 ⁷ / ₁₆	8 ¹ / ₄	16 ¹⁵ / ₁₆	14 ¹³ / ₁₆	⁵ / ₁₆	43 ³ / ₄	11 ¹³ / ₁₆	11 ¹³ / ₁₆	602
		100CLFU618	18.5	25	30 ⁷ / ₈	17 ¹ / ₄	22 ¹ / ₄	8 ¹¹ / ₁₆	17 ¹¹ / ₁₆	14 ¹³ / ₁₆	⁵ / ₁₆	44 ¹³ / ₁₆	12 ⁵ / ₈	11 ¹³ / ₁₆	677
	3/4	100CLFU622	22	30	30 ⁷ / ₈	17 ¹ / ₄	22 ¹ / ₄	8 ¹¹ / ₁₆	17 ¹¹ / ₁₆	14 ¹³ / ₁₆	⁵ / ₁₆	44 ¹³ / ₁₆	12 ⁵ / ₈	11 ¹³ / ₁₆	736
		100CLFU630	30	40	33 ³ / ₄	19 ⁹ / ₁₆	23 ⁵ / ₈	9 ⁵ / ₈	19 ⁷ / ₈	19 ⁷ / ₁₆	⁵ / ₁₆	55 ³ / ₄	14 ³ / ₁₆	19 ¹ / ₄	1001
		100CLFU637	37	50	33 ³ / ₄	19 ⁹ / ₁₆	23 ⁵ / ₈	9 ⁵ / ₈	19 ⁷ / ₈	19 ⁷ / ₁₆	⁵ / ₁₆	59 ⁵ / ₁₆	14 ³ / ₁₆	20 ⁵ / ₁₆	1171

Dimensions: mm

PHASE	SIZE Ø	MODEL	OUTPUT		PUMP & MOTOR								WEIGHT kg		
			KW	HP	A	B	C	D	E	F	G	H		J	L
THREE	80/100	100CLFU61.5	1.5	2	553	267	420	134	305	275	8	760	200	220	77
		100CLFU62.2	2.2	3	581	282	440	141	325	275	8	782	220	220	90
		100CLFU63.7	3.7	5	581	282	440	141	325	275	8	822	220	220	98
	100/150	100CLFU67.5	7.5	10	725	398	525	200	410	381	10	951	280	290	179
		100CLFU611	11	15	725	398	525	200	410	381	8	1044	280	290	216
		100CLFU615	15	20	755	417	545	210	430	377	8	1099	300	300	273
		100CLFU618	18.5	25	784	438	565	220	450	377	8	1139	320	300	307
	80/100	100CLFU622	22	30	784	438	565	220	450	377	8	1139	320	300	334
		100CLFU630	30	40	845	497	600	245	485.5	493	8	1416	360	490	454
		100CLFU637	37	50	845	497	600	245	485.5	493	8	1506	360	516	531

***Note:** All dimensions are based on 4" discharge.



Model CLFU

EBARA PRO Cast Sewage Pumps

Dimensions

100CLMFU, 3 to 5HP

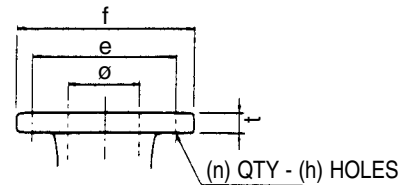
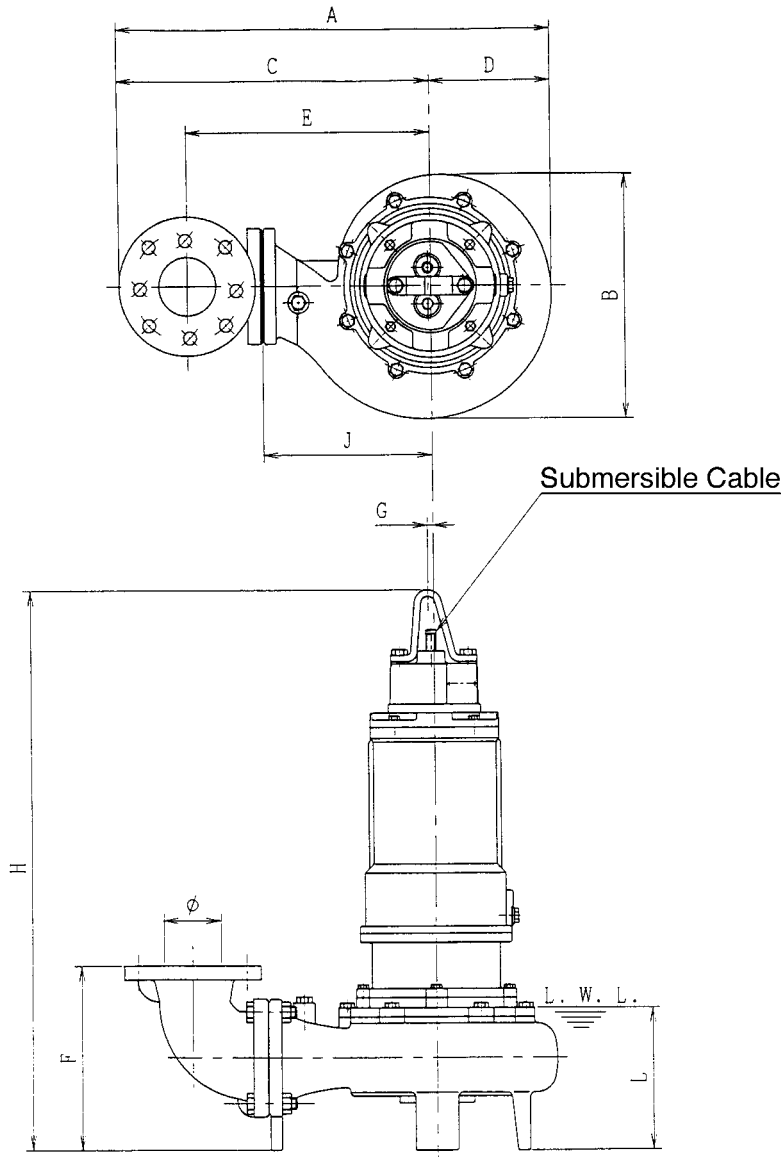

Flange (ANSI 125 PSI F.F)

inch					
ø	e	f	t	n	h
4	7 ¹ / ₂	9	¹⁵ / ₁₆	8	³ / ₄

mm					
ø	e	f	t	n	h
100	191	229	24	8	19

Dimensions: inch

PHASE	SIZE ø	MODEL	OUTPUT		PUMP & MOTOR									WEIGHT Lb	
			kW	HP	A	B	C	D	E	F	G	H	J		L
THREE	3/4	100CLMFU62.2	2.2	3	24 ⁹ / ₁₆	13 ³ / ₁₆	17 ¹⁵ / ₁₆	6 ⁵ / ₈	13 ³ / ₈	9 ¹³ / ₁₆	⁵ / ₁₆	30 ¹ / ₄	9 ¹ / ₄	8 ¹ / ₁₆	210
		100CLMFU63.7	3.7	5	24 ⁹ / ₁₆	13 ³ / ₁₆	17 ¹⁵ / ₁₆	6 ⁵ / ₈	13 ³ / ₈	9 ¹³ / ₁₆	⁵ / ₁₆	31 ¹³ / ₁₆	9 ¹ / ₄	8 ¹ / ₁₆	210

Dimensions: mm

PHASE	SIZE ø	MODEL	OUTPUT		PUMP & MOTOR									WEIGHT kg	
			kW	HP	A	B	C	D	E	F	G	H	J		L
THREE	80/100	100CLMFU62.2	2.2	3	624	335	455	169	340	250	8	768	235	205	95
		100CLMFU63.7	3.7	5	624	335	455	169	340	250	8	808	235	205	95



Model CLFU

EBARA PRO Cast Sewage Pumps

Dimensions

Model CLFU with Quick Discharge Connector

50CLFU, 2HP

80CLFU, 2HP

100CLFU, 2 to 5HP

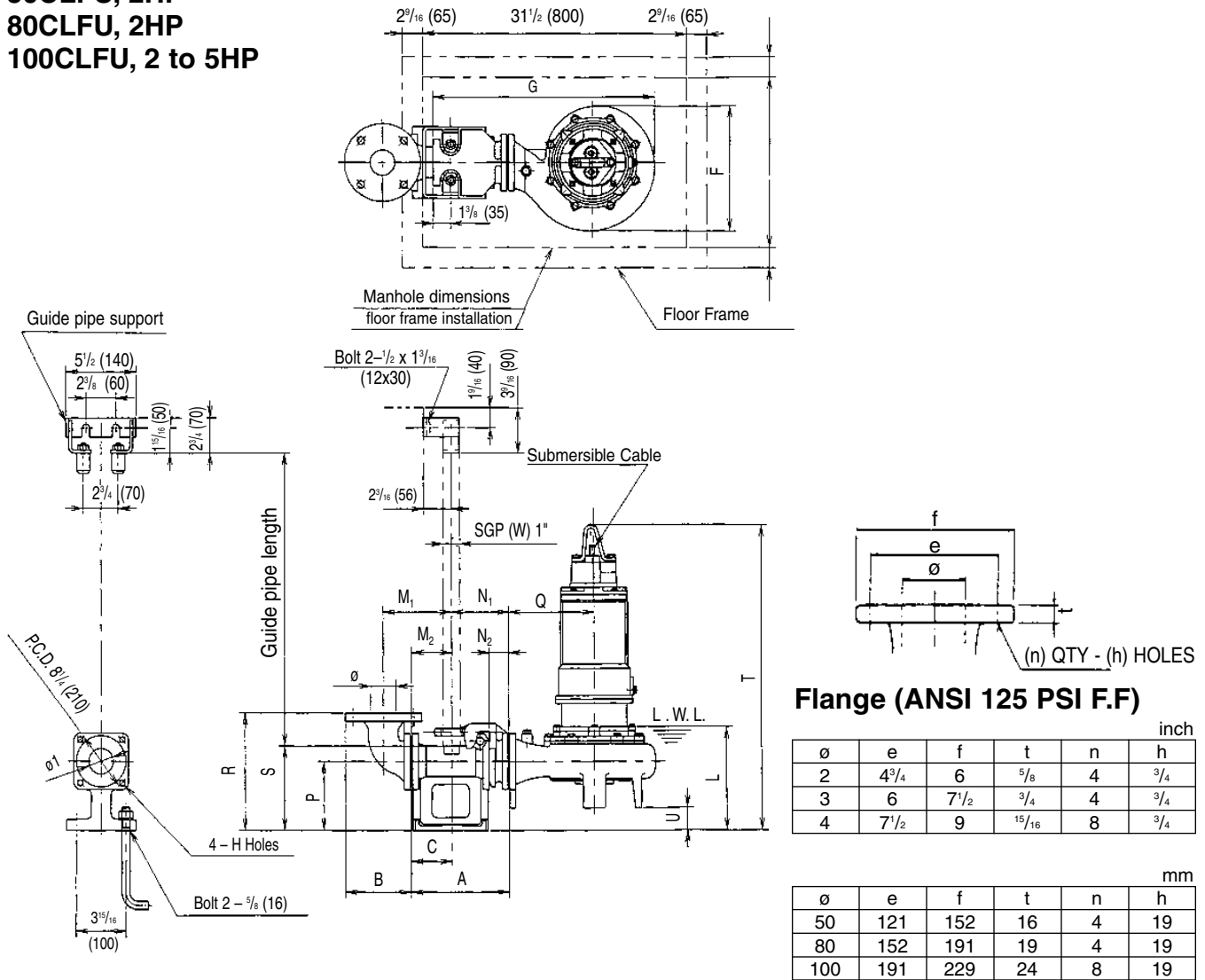

Flange (ANSI 125 PSI F.F)

inch					
ø	e	f	t	n	h
2	4 3/4	6	5/8	4	3/4
3	6	7 1/2	3/4	4	3/4
4	7 1/2	9	15/16	8	3/4

mm					
ø	e	f	t	n	h
50	121	152	16	4	19
80	152	191	19	4	19
100	191	229	24	8	19

Dimensions: inch

PHASE	SIZE ø	MODEL	OUTPUT		QDC MODEL	QDC													PUMP & MOTOR						WEIGHT Lb	
			KW	HP		A	B	C	H	J	M ₁	M ₂	N ₁	N ₂	P	R	S	ø1	F	G	L	Q	T	U	PUMP	QDC
THREE	2/3	50CLFU61.5	1.5	2	LM65	8 7/16	6	3 3/4	1/2	5 1/2	6 5/16	3 3/4	4 3/4	1 3/4	5 11/16	9 15/16	7 1/2	2 1/2	10 1/8	18 3/4	8 1/4	7 1/16	29 5/8	1 15/16	132	31
		80CLFU61.5	1.5	2	LM80	8 7/16	6 5/8	3 9/16	9/16	6 1/8	6 1/2	3 9/16	4 15/16	1 15/16	6 7/8	11 1/4	9 1/16	3	11 1/2	20 1/8	9 5/8	8 1/4	31 1/16	2 9/16	148	37
	3/4	100CLFU61.5	1.5	2	LM80	8 7/16	8 1/4	3 9/16	9/16	6 1/8	7 11/16	3 9/16	4 15/16	1 15/16	6 7/8	11 13/16	9 1/16	3	10 1/2	19 1/16	9 5/8	7 7/8	30 7/8	1	170	37
		100CLFU62.2	2.2	3	LM80	8 7/16	8 1/4	3 9/16	9/16	6 1/8	7 11/16	3 9/16	4 15/16	1 15/16	6 7/8	11 13/16	9 1/16	3	11 1/8	20 1/2	9 5/8	8 11/16	31 3/4	1	199	37
		100CLFU63.7	3.7	5	LM80	8 7/16	8 1/4	3 9/16	9/16	6 1/8	7 11/16	3 9/16	4 15/16	1 15/16	6 7/8	11 13/16	9 1/16	3	11 1/8	20 1/2	9 5/8	8 11/16	33 3/8	1	217	37

Dimensions: mm

PHASE	SIZE ø	MODEL	OUTPUT		QDC MODEL	QDC													PUMP & MOTOR						WEIGHT kg	
			KW	HP		A	B	C	H	J	M ₁	M ₂	N ₁	N ₂	P	R	S	ø1	F	G	L	Q	T	U	PUMP	QDC
THREE	50/80	50CLFU61.5	1.5	2	LM65	215	153	95	12	140	160	95	120	45	145	250	190	65	257	464	210	180	753	50	60	14
		80CLFU61.5	1.5	2	LM80	215	168	90	15	155	165	90	125	50	175	285	230	80	292	511	245	210	789	65	67	17
	80/100	100CLFU61.5	1.5	2	LM80	215	210	90	15	155	195	90	125	50	175	300	230	80	267	494	245	200	785	25	77	17
		100CLFU62.2	2.2	3	LM80	215	210	90	15	155	195	90	125	50	175	300	230	80	282	521	245	220	807	25	90	17
		100CLFU63.7	3.7	5	LM80	215	210	90	15	155	195	90	125	50	175	300	230	80	282	521	245	220	847	25	98	17



Model CLFU

EBARA PRO Cast Sewage Pumps

Dimensions

**Model CLFU with Quick Discharge Connector
80CLMFU, 2 to 5HP**

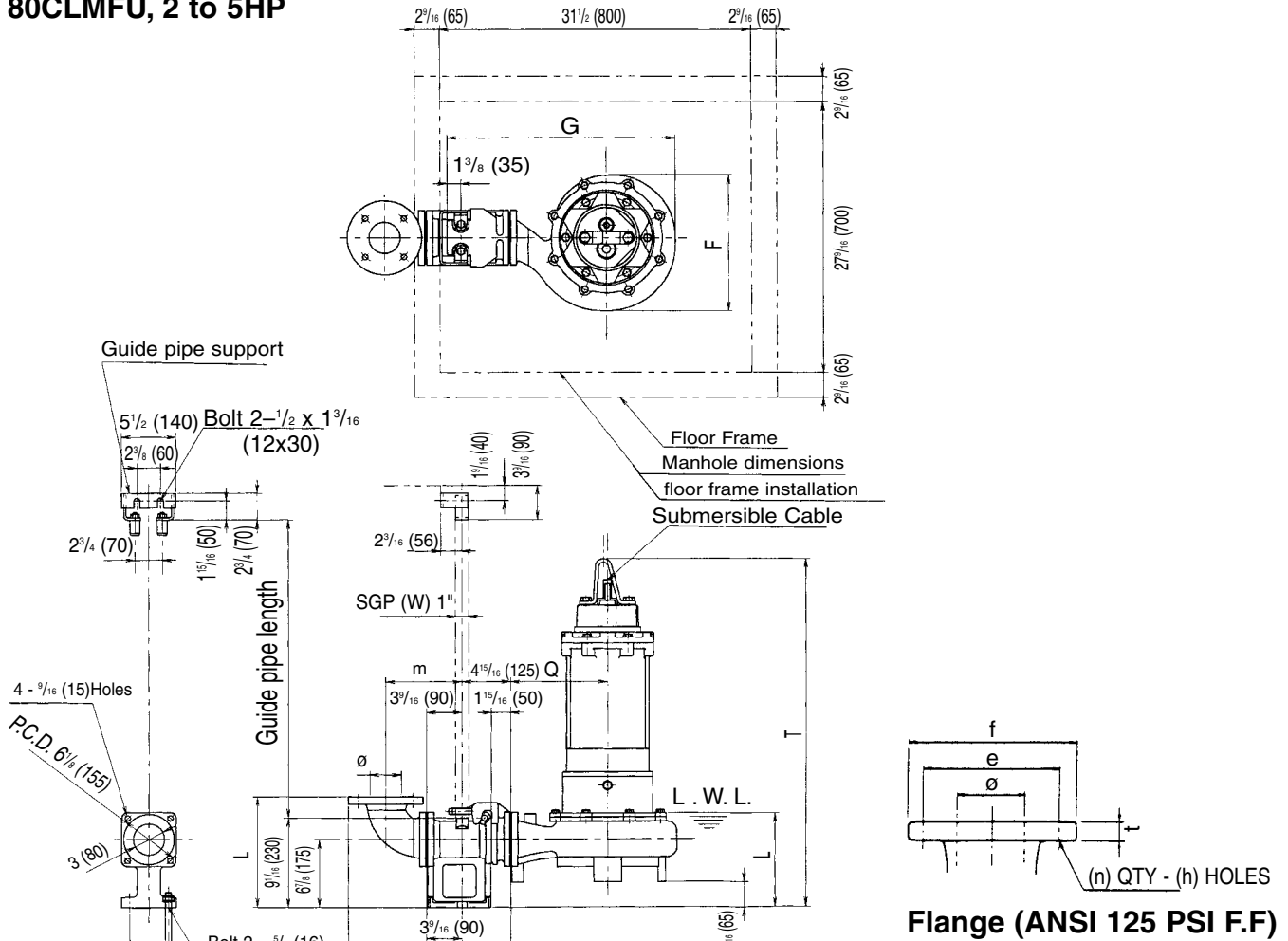

inch							
ø	e	f	t	n	h	r	m
3	6	7 1/2	3/4	4	3/4	11 3/16	6 7/16
4	7 1/2	9	15/16	8	3/4	11 13/16	7 5/8
mm							
ø	e	f	t	n	h	r	m
80	152	191	19	4	19	284	164
100	191	229	24	8	19	300	194

Dimensions: inch

PHASE	SIZE ø	PUMP MODEL	OUTPUT		Q.D.C. MODEL	PUMP & MOTOR					WEIGHT Lb	
			kW	HP		F	G	L	Q	T	PUMP	Q.D.C.
THREE	3/4	80CLMFU61.5	1.5	2	LM80	11 1/2	20 5/16	9 3/16	8 1/4	31 1/16	157	37
		80CLMFU62.2	2.2	3	LM80	11 1/2	20 5/16	9 15/16	8 1/4	32 1/16	187	37
		80CLMFU63.7	3.7	5	LM80	12 1/8	21	9 15/16	8 11/16	33 3/8	205	37

Dimensions: mm

PHASE	SIZE ø	PUMP MODEL	OUTPUT		Q.D.C. MODEL	PUMP & MOTOR					WEIGHT kg	
			kW	HP		F	G	L	Q	T	PUMP	Q.D.C.
THREE	80/100	80CLMFU61.5	1.5	2	LM80	292	516	250	210	789	71	17
		80CLMFU62.2	2.2	3	LM80	292	516	253	210	815	85	17
		80CLMFU63.7	3.7	5	LM80	308	534	252	220	854	93	17



Model CLFU

EBARA PRO Cast Sewage Pumps

Dimensions

**Model CLFU with Quick Discharge Connector
80CLFU, 3 to 5HP**

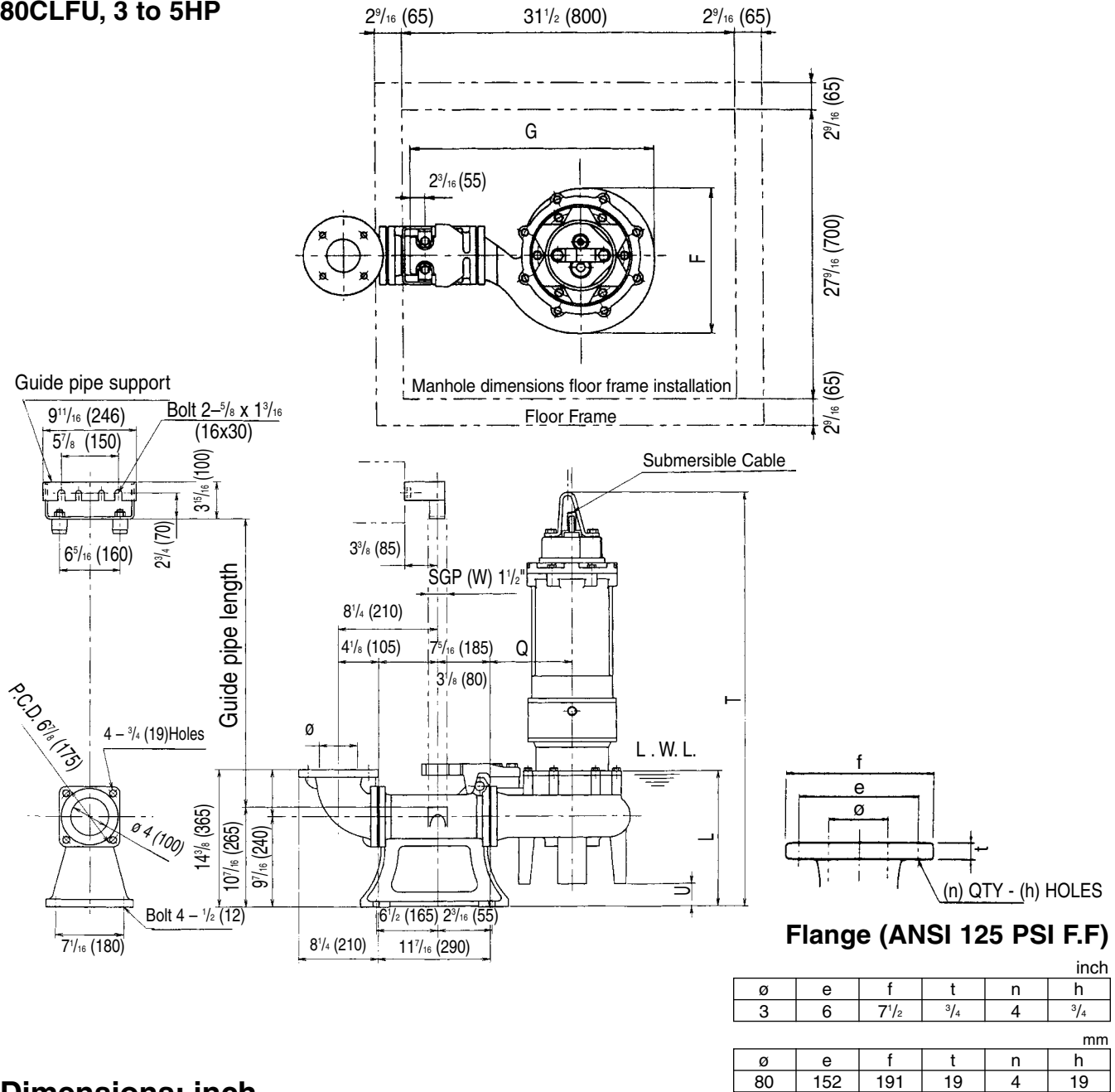

Dimensions: inch

PHASE	SIZE ø	MODEL	OUTPUT		Q.D.C. MODEL	PUMP & MOTOR						WEIGHT Lb	
			KW	HP		F	G	L	Q	T	U	PUMP	Q.D.C.
THREE	3/4	80CLFU62.2	2.2	3	LL100	13 ³ / ₁₆	25 ³ / ₈	12 ⁵ / ₈	9 ¹ / ₄	34 ³ / ₄	4 ¹ / ₂	209	101
		80CLFU63.7	3.7	5	LL100	13 ³ / ₁₆	25 ³ / ₈	12 ⁵ / ₈	9 ¹ / ₄	36 ⁵ / ₁₆	4 ¹ / ₂	209	101

Dimensions: mm

PHASE	SIZE ø	MODEL	OUTPUT		Q.D.C. MODEL	PUMP & MOTOR						WEIGHT kg	
			KW	HP		F	G	L	Q	T	U	PUMP	Q.D.C.
THREE	80/100	80CLFU62.2	2.2	3	LL100	335	644	320	235	883	115	95	46
		80CLFU63.7	3.7	5	LL100	335	644	320	235	923	115	95	46



Model CLFU

EBARA PRO Cast Sewage Pumps

Dimensions

**Model CLFU with Quick Discharge Connector
100CLMFU, 3 to 5HP**

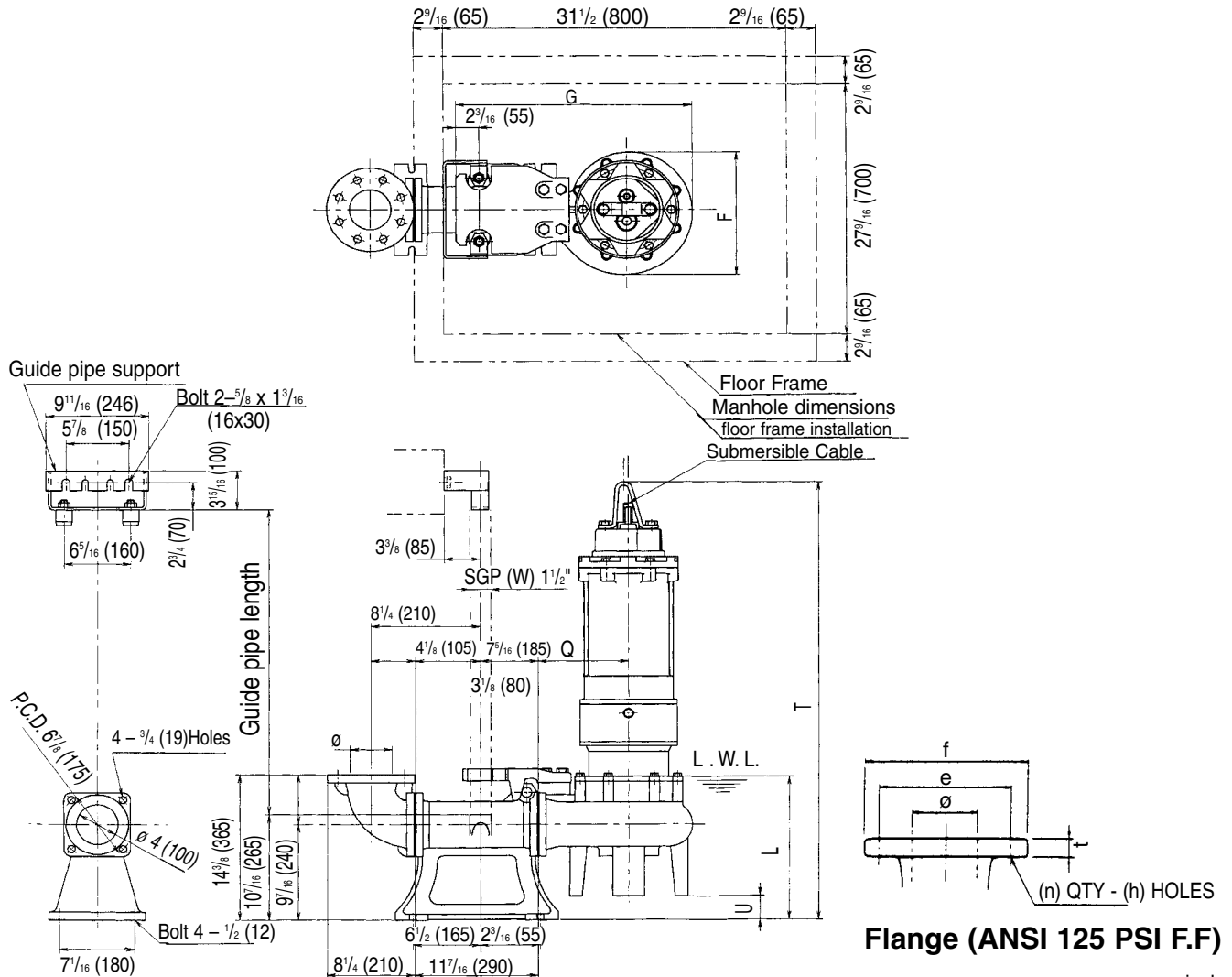

Flange (ANSI 125 PSI F.F)

inch					
ø	e	f	t	n	h
4	7 ¹ / ₂	9	1 ⁵ / ₁₆	8	3/4
mm					
ø	e	f	t	n	h
100	191	229	24	8	19

Dimensions: inch

PHASE	SIZE ø	MODEL	OUTPUT		Q.D.C. MODEL	PUMP & MOTOR						WEIGHT Lb	
			kW	HP		F	G	L	Q	T	U	PUMP	Q.D.C.
THREE	3/4	100CLMFU62.2	2.2	3	LL100	13 ³ / ₁₆	25 ⁵ / ₈	12 ⁵ / ₈	9 ¹ / ₄	34 ³ / ₄	4 ¹ / ₂	209	101
		100CLMFU63.7	3.7	5	LL100	13 ³ / ₁₆	25 ⁵ / ₈	12 ⁵ / ₈	9 ¹ / ₄	36 ⁵ / ₁₆	4 ¹ / ₂	209	101

Dimensions: mm

PHASE	SIZE ø	MODEL	OUTPUT		Q.D.C. MODEL	PUMP & MOTOR						WEIGHT kg	
			kW	HP		F	G	L	Q	T	U	PUMP	Q.D.C.
THREE	80/100	100CLMFU62.2	2.2	3	LL100	335	644	320	235	883	115	95	46
		100CLMFU63.7	3.7	5	LL100	335	644	320	235	923	115	95	46



Model CLFU

EBARA PRO Cast Sewage Pumps

Sectional View

2 to 5HP

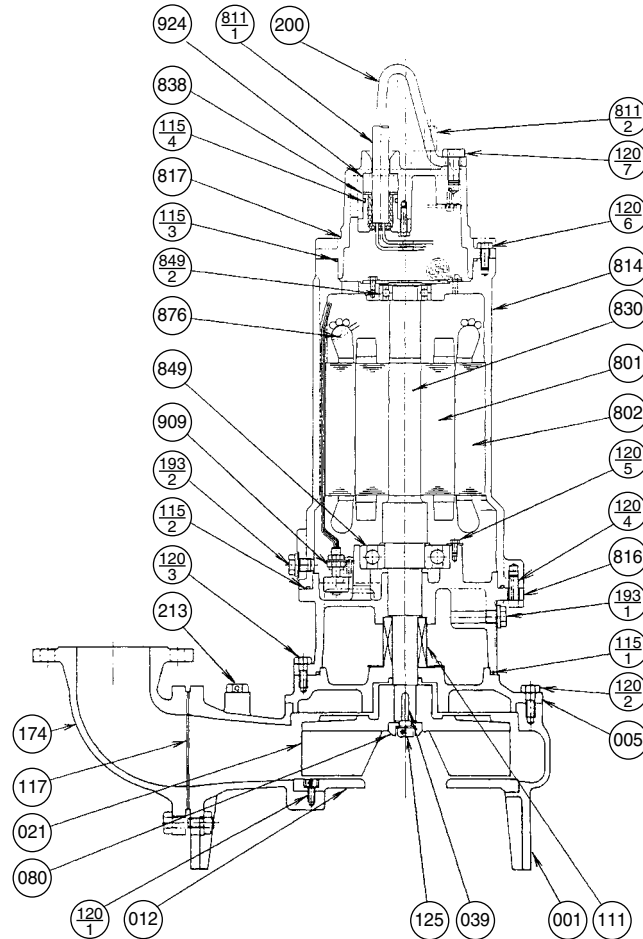

PART NO.	PART NAME	MATERIAL	ASTM, AISI CODE	NO. FOR 1 UNIT
001	CASING	CAST IRON	A48 Class 30	1
005	INTERMEDIATE CASING	CAST IRON	A48 Class 30	1
†012	SUCTION COVER	CAST IRON	A48 Class 30	1
†021	IMPELLER	CAST IRON	A48 Class 30	1
039	KEY	420 STAINLESS	AISI420	1
080	BUSHING	STEEL	A283 Grade D	1
†111	MECHANICAL SEAL	—		1 SET
†115-1	O-RING	RUBBER (NBR)		1
†115-2	O-RING	RUBBER (NBR)		1
†115-3	O-RING	RUBBER (NBR)		1
†115-4	O-RING	RUBBER (NBR)		2
†117	GASKET			1
120-1	BOLT	304 STAINLESS	AISI304	4
120-2	BOLT	304 STAINLESS	AISI304	8
120-3	BOLT	304 STAINLESS	AISI304	4
120-4	BOLT	304 STAINLESS	AISI304	4
120-5	BOLT	304 STAINLESS	AISI304	3
120-6	BOLT	304 STAINLESS	AISI304	4
120-7	BOLT	304 STAINLESS	AISI304	2
125	BOLT	304 STAINLESS	AISI304	1

PART NO.	PART NAME	MATERIAL	ASTM, AISI CODE	NO. FOR 1 UNIT
174	DISCHARGE ELBOW	CAST IRON	A48 Class 30	1
193-1	PLUG	304 STAINLESS	AISI304	1
193-2	PLUG	304 STAINLESS	AISI304	1
200	LIFTING HANGER	STEEL	A283 Grade D	1
213	AIR VENT VALVE	BRASS	B36 No. 272	1
801	ROTOR	—		1
802	STATOR	—		1
811-1	POWER CABLE	—		1
811-2	CONTROL CABLE	—		1
814	MOTOR COVER	CAST IRON	A48 Class 30	1
816	BRACKET	CAST IRON	A48 Class 30	1
817	BRACKET	CAST IRON	A48 Class 30	1
830	SHAFT	403 STAINLESS	AISI403	1
838	WASHER	304 STAINLESS	AISI304	2
†849-1	BALL BEARING	—		1
†849-2	BALL BEARING	—		1
876	MOTOR PROTECTOR	—		3
909	LEAKAGE DETECTOR	—		1
924	PACKING	RUBBER (NBR)		2

Motors are purchased as a complete unit

†: Recommended spare parts

