

**Model CGUII/CGFU****EBARA PRO Cast Grinder Pumps****Contents****Model**

32CGUII61.5S

32CGFU61.5S

32CGFU61.5

50CGFU62.2S

50CGFU62.2

50CGFU63.7S

50CGFU63.7

<b>Section</b>	<b>Page</b>
Specifications	1602
Selection Chart	1603
Performance Curves	1606
Dimensions	1608
Sectional View	1613
QDC Information	1900
Motor Data	2000
motor electrical specifications	
cable data	
wiring diagrams	
motor electrical data	

# CGUII/CGFU

Model CGUII/CGFU

EBARA PRO Cast Grinder Pumps

Model Designation

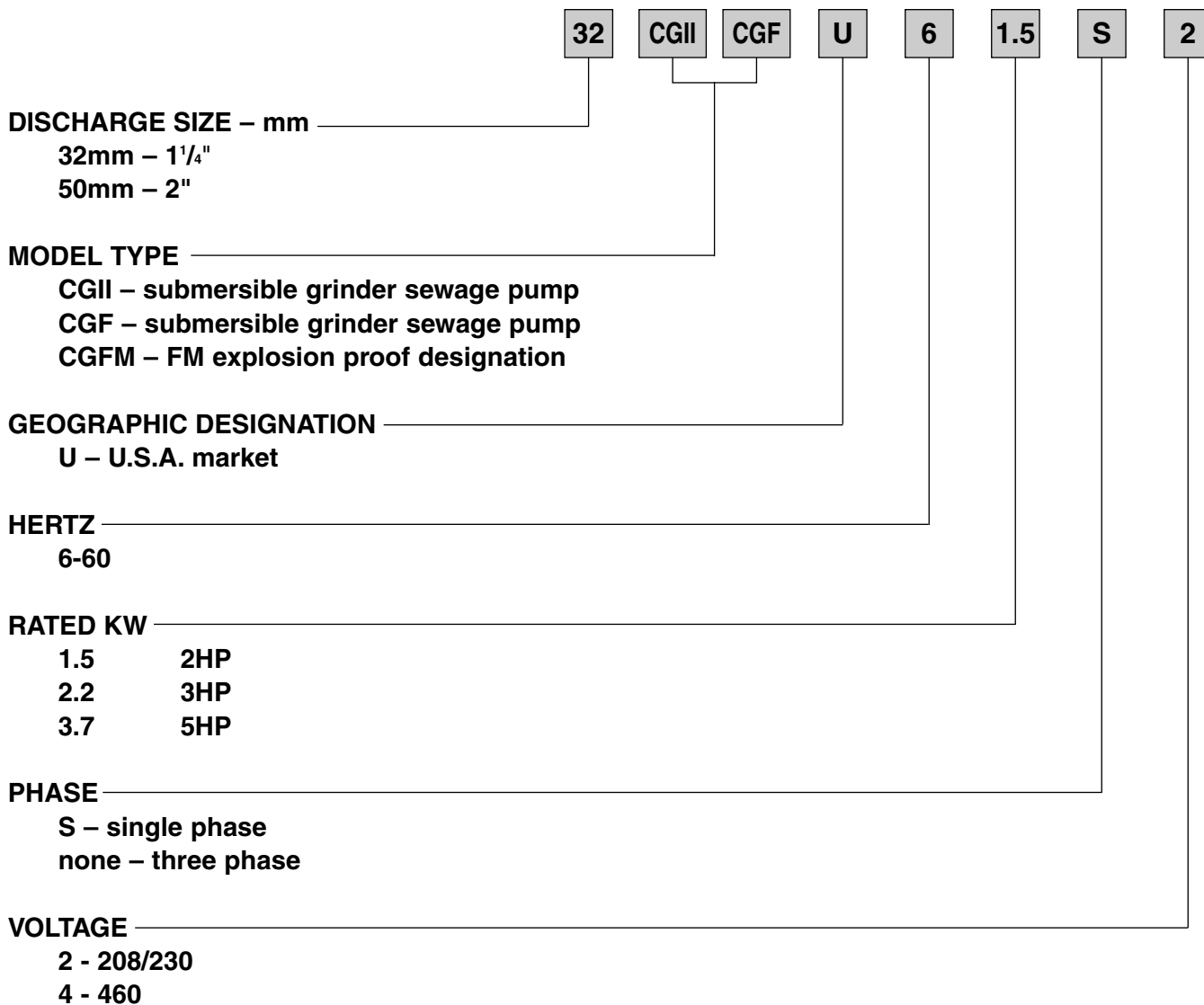

**Model CGUII**

**EBARA PRO Cast Grinder Pumps**

**Specification**

	<b>Standard</b>	<b>Optional</b>
Size	1¼ inch	
Range of HP Range of Performance	2 HP Single Phase Capacity 5 to 30 GPM Head 27 to 112 feet	
<b>Limitation</b> Maximum Water Temperature	104°F (40°C)	
<b>Synchronous Speed</b>	3600 RPM	
<b>Materials</b> Casing Impeller Grinder Impeller Grinder Disk Shaft Motor Frame Fastener	Cast Iron Cast Iron High Chrome Cast Iron HRC 60 High Chrome Cast Iron HRC 60 403 Stainless Steel Cast Iron 304 Stainless Steel	
<b>Mechanical Seal</b> Material – Upper Side Material – Lower Side Impeller Type Bearing – Upper/Lower Side Motor Single Phase Motor Protection Single Phase  Accessories	Double Mechanical Seal Silicon Carbide/Silicon Carbide Silicon Carbide/Silicon Carbide Vortex Impeller Prelubricated Ball Bearing Air-filled, Insulation Class F 208/230V  Built-in Auto Cut, overload, no load, out of phase, and single phasing protection Submersible cable 33 ft.	66 ft. QDC System

Selection Chart

Single phase

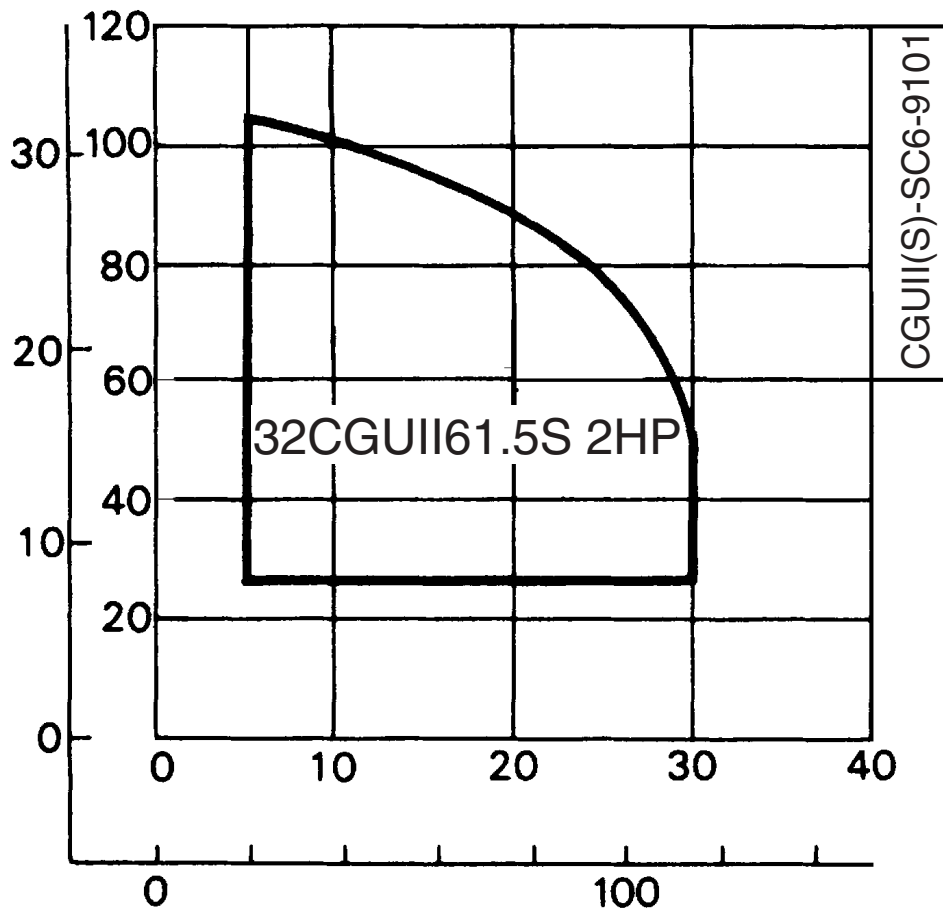

**Model CGFU****EBARA PRO Cast Grinder Pumps****Specification**

	<b>Standard</b>	<b>Optional</b>
Size	1 1/4, 2 inch	
Range of HP Range of Performance	2 to 5HP Single and Three Phase Capacity 5 to 80 GPM Head 27 to 148 feet	
<b>Limitation</b> Maximum Water Temperature	104°F (40°C)	
<b>Synchronous Speed</b>	3600 RPM	
<b>Materials</b> Casing Impeller Grinder Impeller Grinder Disk Shaft Motor Frame Fastener	Cast Iron Cast Iron High Chrome Cast Iron HRC 60 High Chrome Cast Iron HRC 60 403 Stainless Steel Cast Iron 304 Stainless Steel	
<b>Mechanical Seal</b> Material – Upper Side Material – Lower Side Impeller Type Bearing – Upper/Lower Side Motor Single Phase Three Phase Motor Protection  Accessories	Double Mechanical Seal Silicon Carbide/Silicon Carbide Silicon Carbide/Silicon Carbide Vortex Impeller Prelubricated Ball Bearing Insulation Class F 208/230V 208/230/460V  Built-in Thermal Detector – Klixon Built-in Mechanical Seal Leakage Detector Submersible cable 33 ft.	FM Explosion Proof Class 1, Division 1, Group C, D  ____ ft. (customer specified) QDC System

**Selection Chart**

**Single and Three Phase**

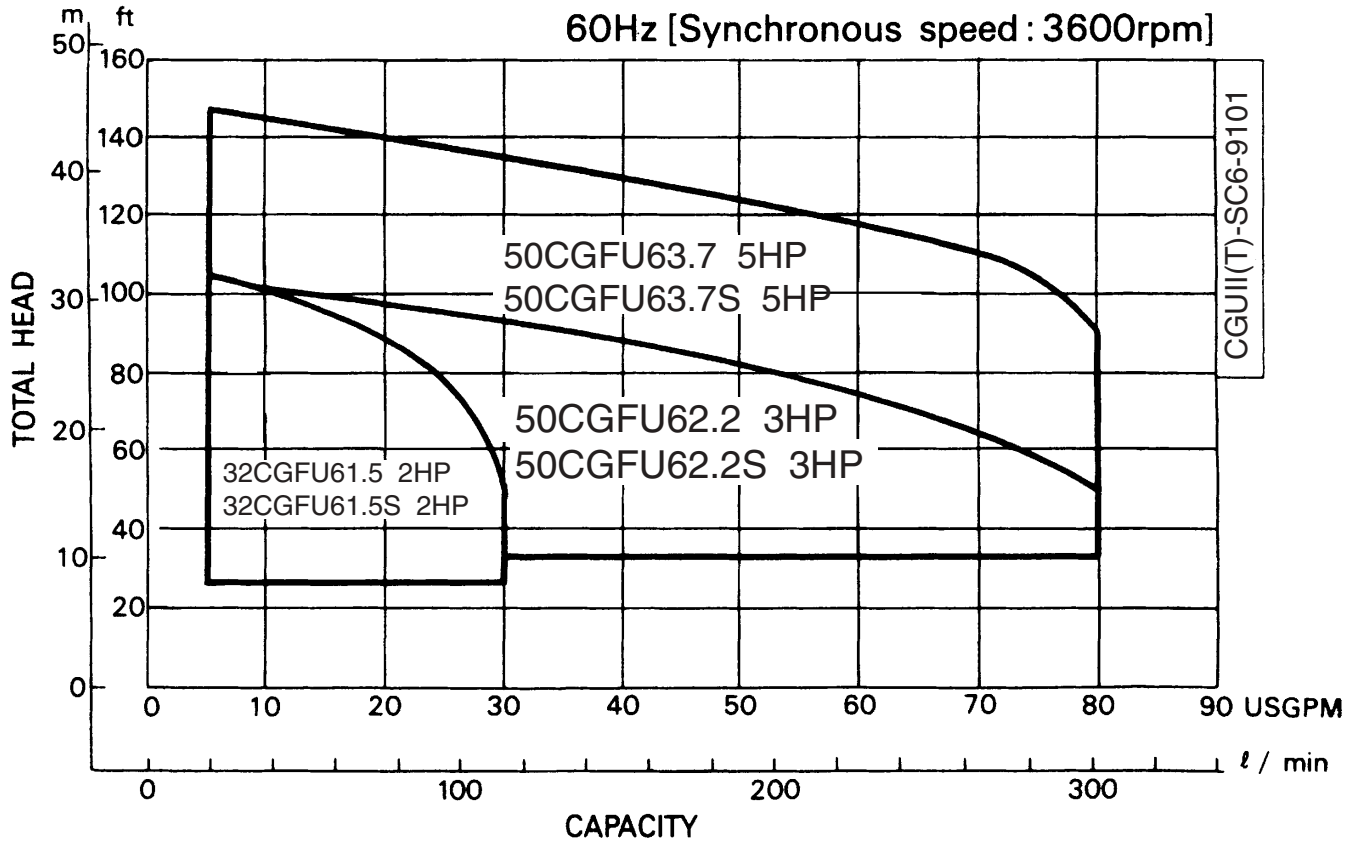

**Model CGUI/CGFU**

**EBARA PRO Cast Grinder Pumps**

**Performance Curves**

**32CGUI61.5S (2HP) Synchronous Speed: 3600 RPM**

**1 1/4 inch Discharge**

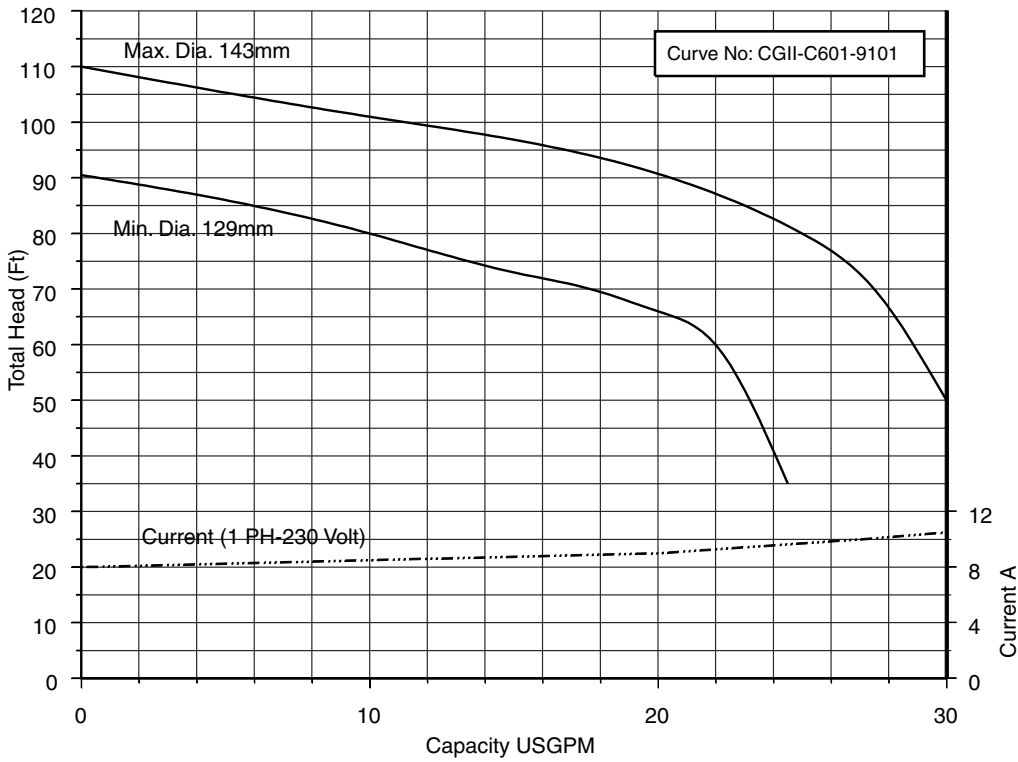

**32CGF61.5S 32CGFU61.5 (2HP) Synchronous Speed: 3600 RPM 1 1/4 inch Discharge**

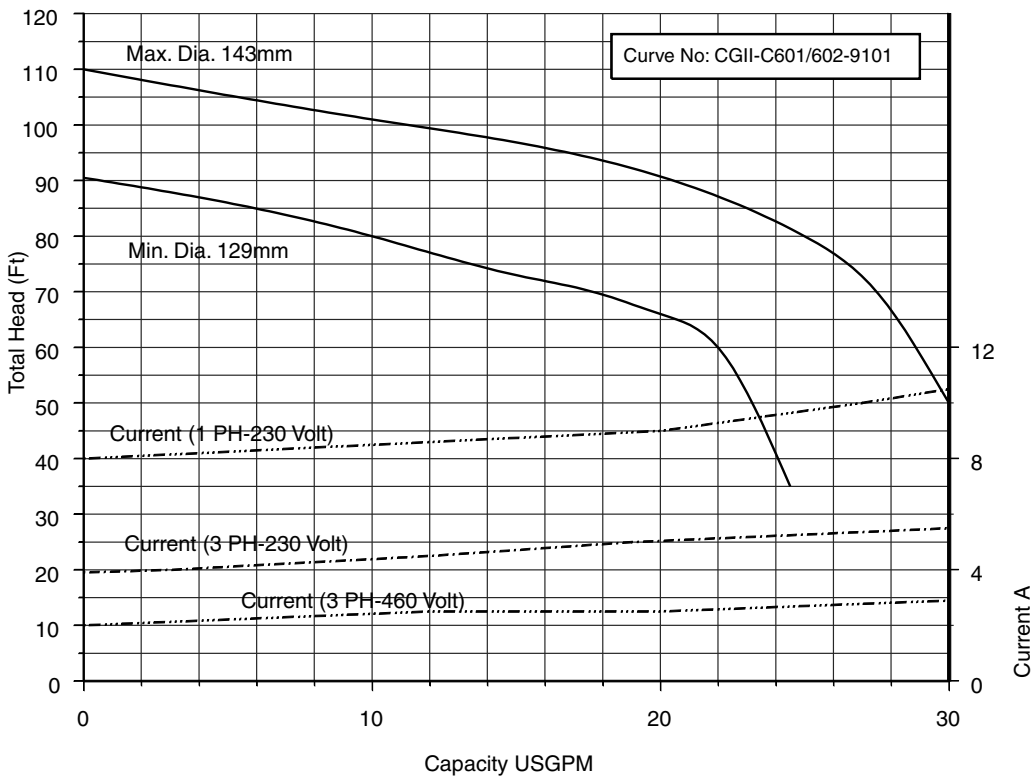

**50CGF62.2S 50CGFU62.2 (3HP) Synchronous Speed: 3600 RPM 2 inch Discharge**

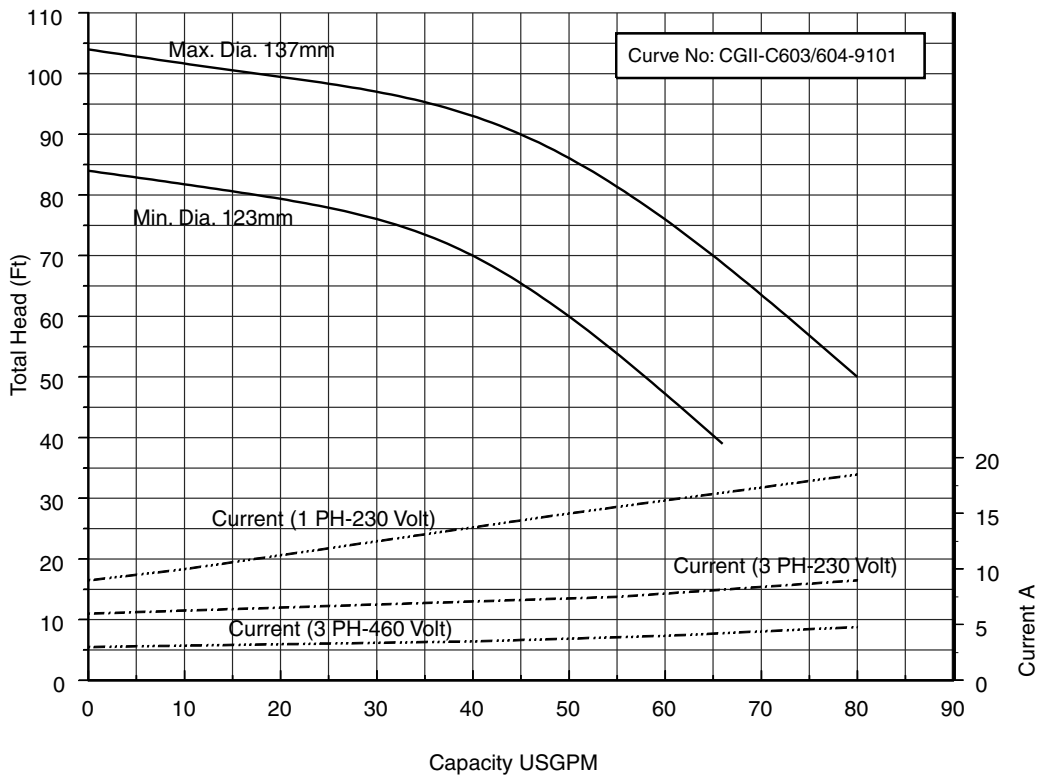

**50CGF63.7S 50CGFU63.7 (5HP) Synchronous Speed: 3600 RPM 2 inch Discharge**

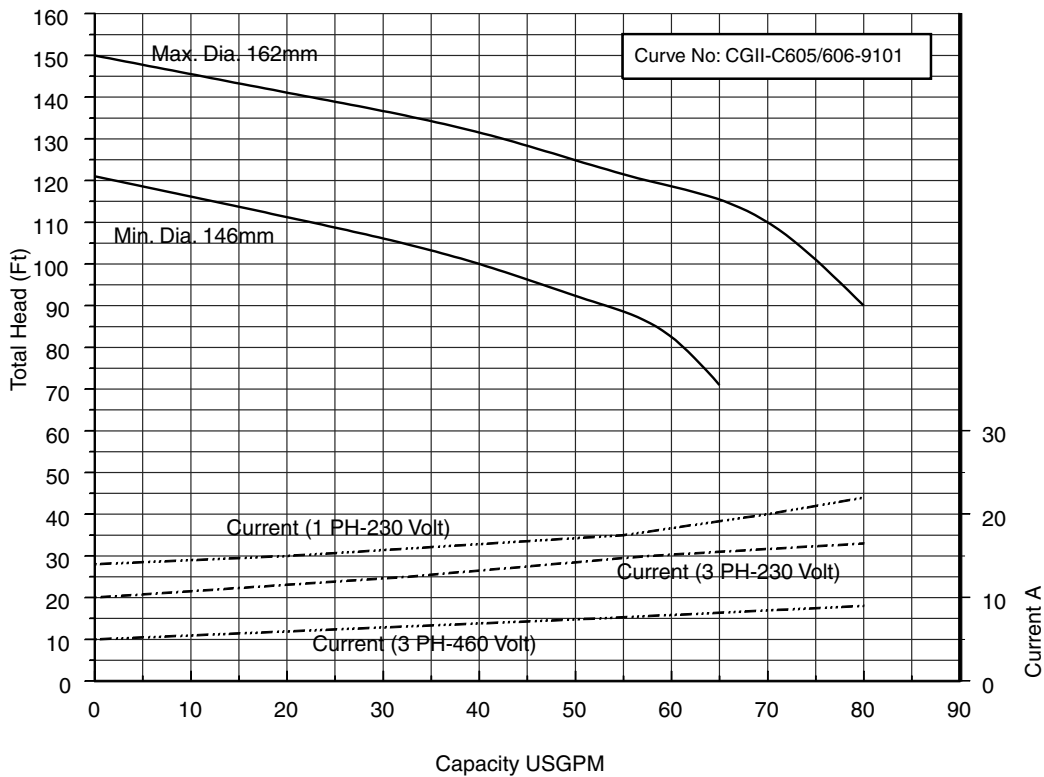

# CGUI/CGFU

## Model CGUI/CGFU

## EBARA PRO Cast Grinder Pumps

### Dimensions

#### Model CGUI, Single Phase

32CGUI

Unit: inch (mm)

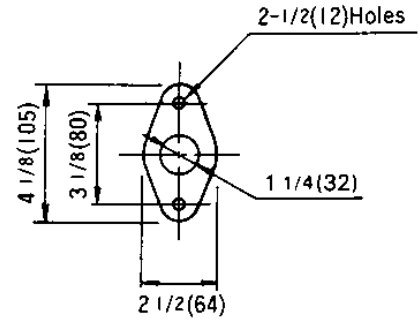
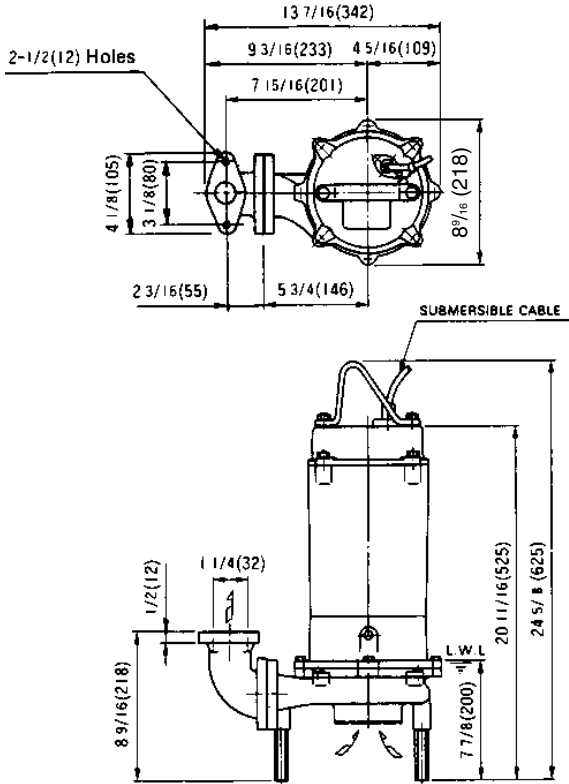

### Flange

MODEL	WEIGHT (Lb/kg)
32CGUI161.5S	93 (42)

**Model CGUI/CGFU**

**EBARA PRO Cast Grinder Pumps**

**Dimensions**

**Model CGFU, Single Phase and Three Phase**

32CGFU, 2HP

50CGFU, 3 to 5HP

Unit: Inch (mm)

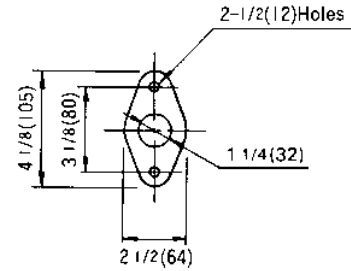
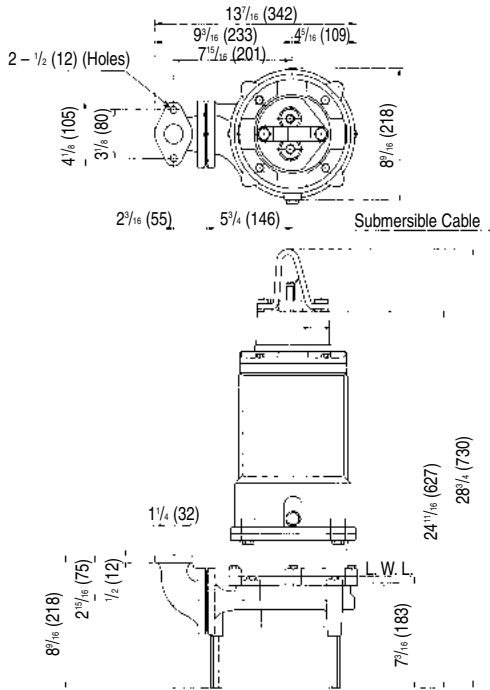

**Flange**

MODEL	WEIGHT – Lb (kg)
32CGFU61.5S	126 (57)
32CGFU61.5	128 (58)

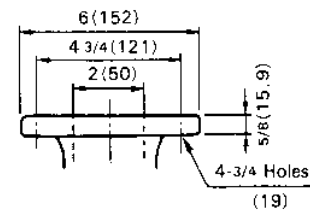
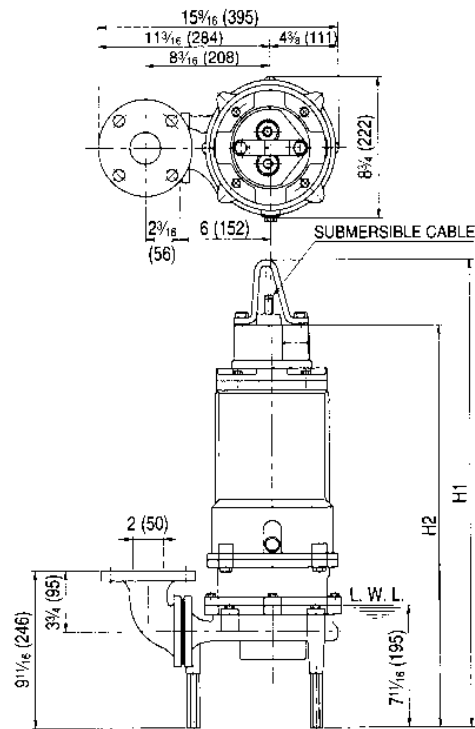

**Flange (ANSI 125 PSI F.F)**

PHASE	MODEL	PUMP & MOTOR		WEIGHT Lb (kg)
		H <sub>1</sub> inch (mm)	H <sub>2</sub> inch (mm)	
SINGLE	50CGFU62.2S	31 11/16 (805)	27 5/8 (702)	174 (79)
	50CGFU63.7S	35 11/16 (907)	31 5/8 (804)	223 (101)
THREE	50CGFU62.2	30 1/8 (765)	26 1/16 (662)	159 (72)
	50CGFU63.7	31 11/16 (805)	27 5/8 (702)	174 (79)

**Model CGUI/CGFU**

**EBARA PRO Cast Grinder Pumps**

**Dimensions**

**Model CGUI, with Quick Discharge Connector, Single Phase  
32CGUI, 2HP**

**Flange**

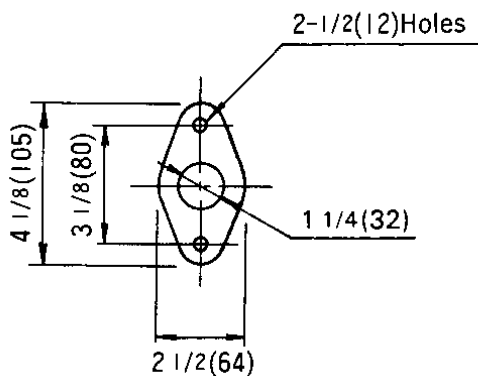

**LM50**

Unit : Inch (mm)

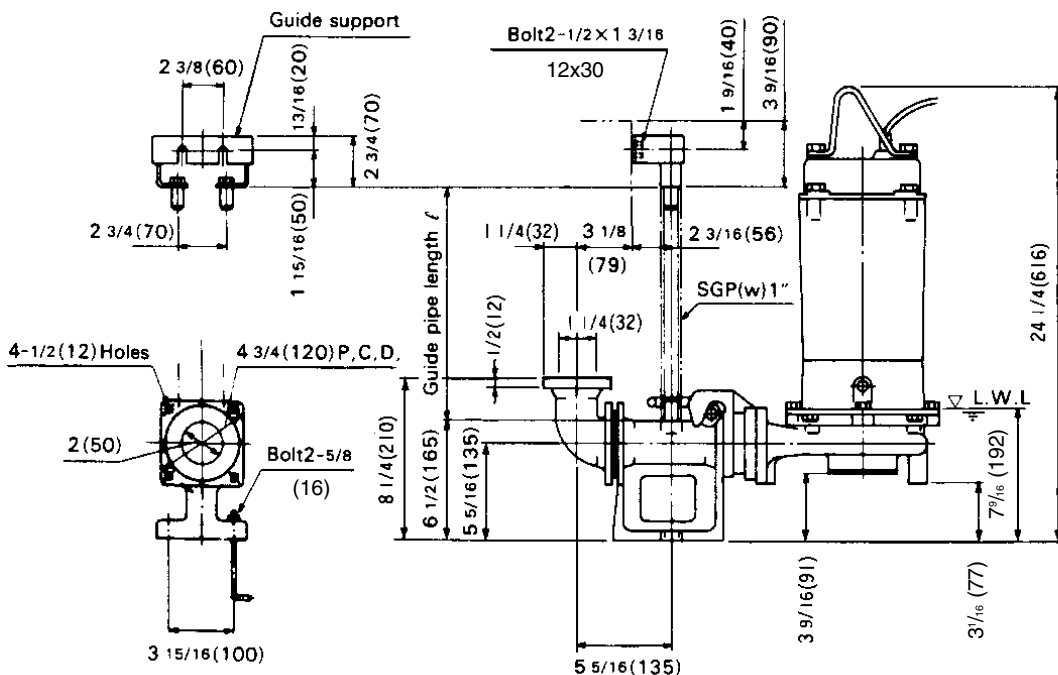
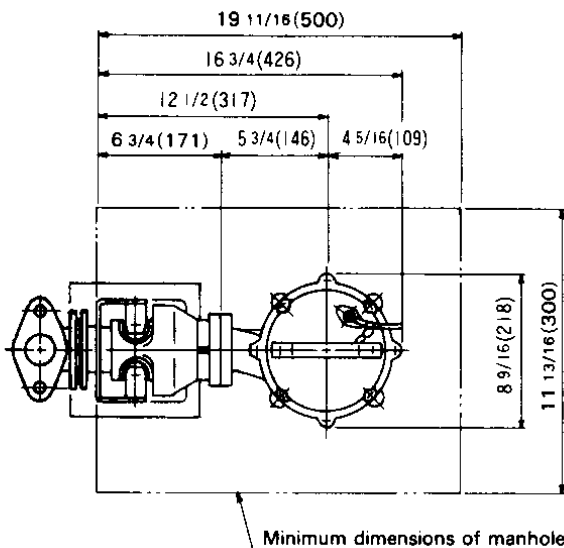

PHASE	MODEL	WEIGHT (Lb)		WEIGHT (kg)	
		Pump	Q.D.C.	Pump	Q.D.C.
SINGLE	32CGUI61.5S	93	24	42	11



**Model CGUI/CGFU**

**EBARA PRO Cast Grinder Pumps**

**Dimensions**

**Model CGFU, with Quick Discharge Connector, Single and Three Phase**  
**50CGFU, 3 to 5HP**

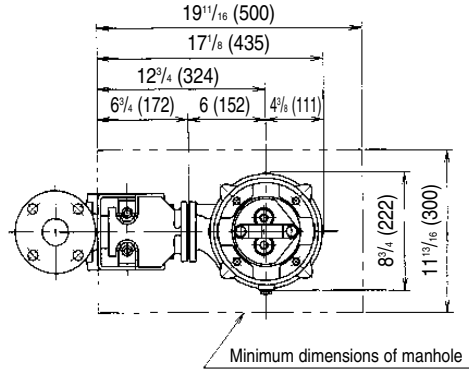

**LM50**

Unit : Inch (mm)

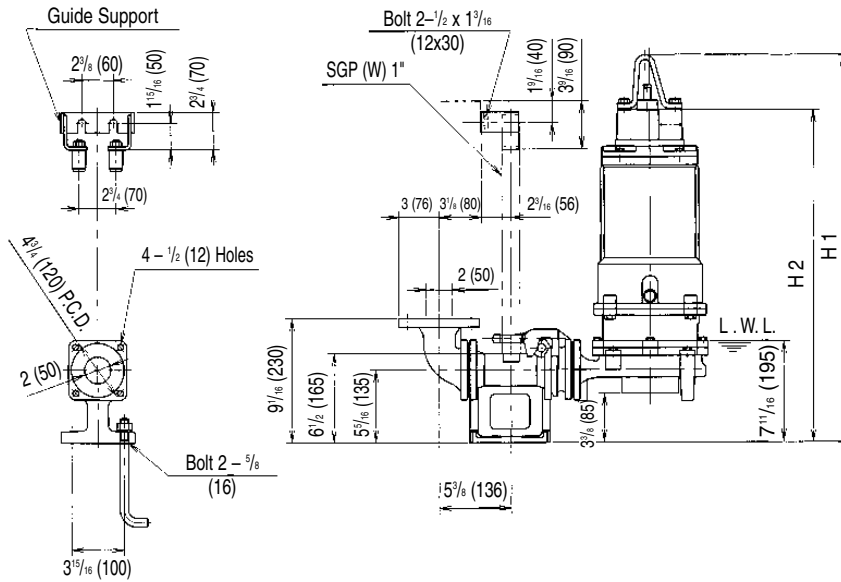

**Flange (ANSI 125 PSI F.F)**

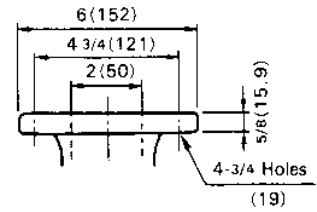

PHASE	MODEL	PUMP & MOTOR		WEIGHT – Lb (kg)	
		H <sub>1</sub> inch (mm)	H <sub>2</sub> inch (mm)	Pump	Q.D.C.
SINGLE	50CGFU62.2S	31 1/16 (789)	27 (686)	174 (79)	24 (11)
	50CGFU63.7S	35 1/16 (891)	31 (788)	223 (101)	24 (11)
THREE	50CGFU62.2	29 1/2 (749)	25 7/16 (646)	159 (72)	24 (11)
	50CGFU63.7	31 1/16 (789)	27 (686)	174 (79)	24 (11)

**Model CGUI/CGFU**

**EBARA PRO Cast Grinder Pumps**

**Sectional View**

**Single Phase  
32CGUI**

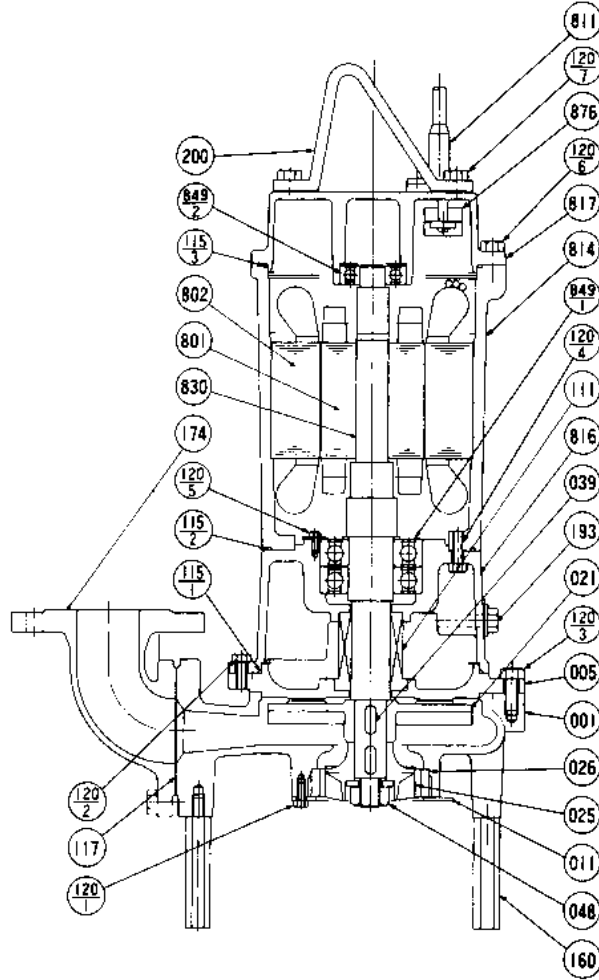

PART NO.	PART NAME	MATERIAL	ASTM, AISI CODE	NO. FOR 1 UNIT	PART NO.	PART NAME	MATERIAL	ASTM, AISI CODE	NO. FOR 1 UNIT
001	CASING	CAST IRON	A48 Class 30	1	120-5	BOLT	304 STAINLESS	AISI304	2
005	INTERMEDIATE CASING	CAST IRON	A48 Class 30	1	120-6	BOLT	304 STAINLESS	AISI304	4
011	DISK COVER	304 STAINLESS	AISI304	1	120-7	BOLT	304 STAINLESS	AISI304	2
†021	IMPELLER	CAST IRON	A48 Class 30	1	160	PUMP STAND	STEEL	A283 Grade D	3
†025	GRINDER IMPELLER	CHROME ALLOYED CAST IRON		1	174	DISCHARGE ELBOW	CAST IRON	A48 Class 30	1
†026	CUTTER RING	CHROME ALLOYED CAST IRON		1	193	OIL PLUG	304 STAINLESS	AISI304	1
039	KEY	420 STAINLESS	AISI420	2	200	LIFTING HANGER	STEEL	A283 Grade D	1
048	IMPELLER NUT	304 STAINLESS	AISI304	1	801	ROTOR	—		1
†111	MECHANICAL SEAL	—		1 SET	802	STATOR	—		1
†115-1	O-RING	RUBBER (NBR)		1	†811	SUBMERSIBLE CABLE	—		1
†115-2	O-RING	RUBBER (NBR)		1	814	MOTOR FRAME	CAST IRON	A48 Class 30	1
†115-3	O-RING	RUBBER (NBR)		1	816	BRACKET	CAST IRON	A48 Class 30	1
†117	GASKET			1	817	BRACKET	CAST IRON	A48 Class 30	1
120-1	BOLT	304 STAINLESS	AISI304	4	830	SHAFT	403 STAINLESS	AISI403	1
120-2	BOLT	304 STAINLESS	AISI304	4	†849-1	BALL BEARING	—		1
120-3	BOLT	304 STAINLESS	AISI304	4	†849-2	BALL BEARING	—		1
120-4	BOLT	304 STAINLESS	AISI304	4	876	MOTOR PROTECTOR	—		1

Motors are purchased as a complete unit

†: Recommended spare parts



**Model CGUI/CGFU**

**EBARA PRO Cast Grinder Pumps**

**Sectional View**

**Single and Three Phase**

32CGFU, 2HP

50CGFU 3 to 5HP

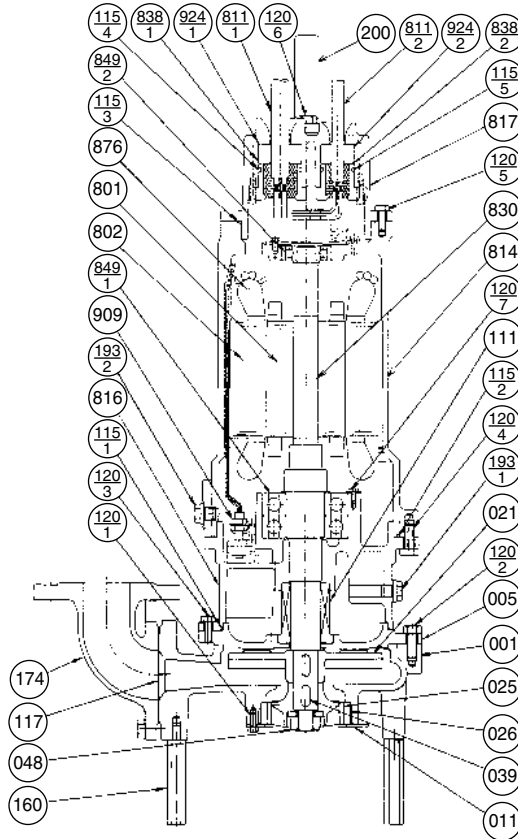

PART NO.	PART NAME	MATERIAL	ASTM, AISI CODE	NO. FOR 1 UNIT	PART NO.	PART NAME	MATERIAL	ASTM, AISI CODE	NO. FOR 1 UNIT
001	CASING	CAST IRON	A48 Class 30	1	160	PUMP STAND	STEEL	A283 Grade D	3
005	INTERMEDIATE CASING	CAST IRON	A48 Class 30	1	174	DISCHARGE ELBOW	CAST IRON	A48 Class 30	1
011	DISK COVER	304 STAINLESS	AISI304	1	193-1	PLUG	304 STAINLESS	AISI304	1
†021	IMPELLER	CAST IRON	A48 Class 30	1	193-2	PLUG	304 STAINLESS	AISI304	1
†025	GRINDER IMPELLER	CHROME ALLOYED CAST IRON		1	200	LIFTING HANGER	STEEL	A283 Grade D	1
†026	CUTTER RING	CHROME ALLOYED CAST IRON		1	801	ROTOR	—		1
039	KEY	420 STAINLESS	AISI420	2	802	STATOR	—		1
048	IMPELLER NUT	304 STAINLESS	AISI304	1	811-1	POWER CABLE	—		1
†111	MECHANICAL SEAL	—		1 SET	811-2	CONTROL CABLE	—		1
†115-1	O-RING	RUBBER (NBR)		1	814	MOTOR FRAME	CAST IRON	A48 Class 30	1
†115-2	O-RING	RUBBER (NBR)		1	816	BRACKET	CAST IRON	A48 Class 30	1
†115-3	O-RING	RUBBER (NBR)		1	817	BRACKET	CAST IRON	A48 Class 30	1
†115-4	O-RING	RUBBER (NBR)		1	830	SHAFT	403 STAINLESS	AISI403	1
†115-5	O-RING	RUBBER (NBR)		1	838-1	WASHER	304 STAINLESS	AISI304	1
†117	GASKET			1	838-2	WASHER	304 STAINLESS	AISI304	1
120-1	BOLT	304 STAINLESS	AISI304	4	†849-1	BALL BEARING	—		1 SET
120-2	BOLT	304 STAINLESS	AISI304	4	†849-2	BALL BEARING	—		1
120-3	BOLT	304 STAINLESS	AISI304	4	876	MOTOR PROTECTOR	—		3
120-4	BOLT	304 STAINLESS	AISI304	4	909	LEAKAGE DETECTOR	—		1
120-5	BOLT	304 STAINLESS	AISI304	4	924-1	PACKING	RUBBER (NBR)		1
120-6	BOLT	304 STAINLESS	AISI304	2	924-2	PACKING	RUBBER (NBR)		1
120-7	BOLT	304 STAINLESS	AISI304	3					

Motors are purchased as a complete unit  
 †: Recommended spare parts



**CALL 1-800-577-8111 FOR SALES AND SUPPORT**